



Vincotech

1500 V Energy Storage Solutions



EMPOWERING YOUR IDEAS

1500 V

PCS (ESS) solutions

Energy storage is increasingly important to meet the **growing demand for clean energy**. As concerns grow about the ecological impact of fossil fuels, energy storage systems help reduce the variable nature of **solar and wind energy production**. It helps increase the resilience of the power grid by improving the **responsiveness to large fluctuations in energy demands**. Efficient energy storage systems can minimize energy loss and **improve the operating efficiency** of the entire system.

Vincotech's high-efficiency power modules feature the latest topologies using optimized combinations of Silicon and Silicon Carbide components. Housed in **low parasitic inductance packages** and using **advanced die attach technology**, they help maximize the performance and reliability of energy storage systems.

1500 V_{DC} PCS DC/AC Modules

flowNPC 2: 1200 V IGBT NPC

Art.Nr: 30-FT12NIA150SH-LG09F08

- / Support 1600 V_{DC} and beyond
- / Tandem diode for optimum cost/performance
- / Easy parallel connection for power expansion
- / Split DCB to reduce the voltage stress
- / flow2 baseplate for easy thermal design

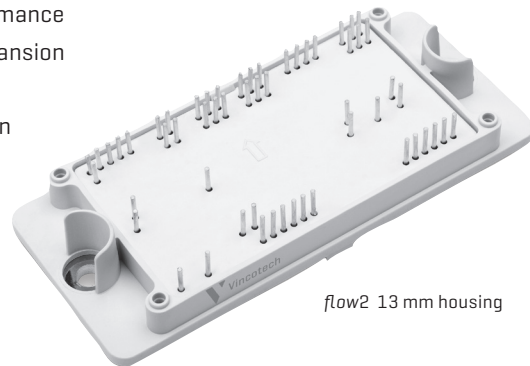

flow2 13 mm housing

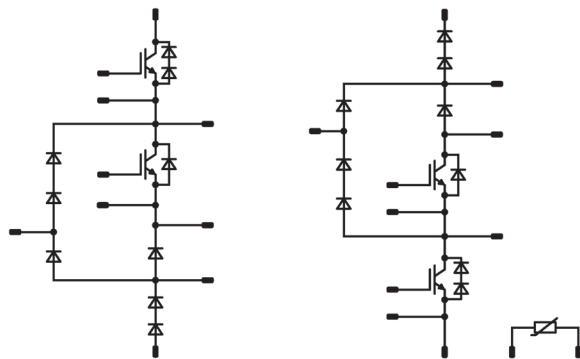

Power rating
50~100 kW
Three-phase
system

Technical trends

/ **High efficiency**
NPC or ANPC

/ **High switching frequency**
16kHz, NPC or ANPC

/ **High power density**
Modular 50 kW to 200+ kW design

/ **High reliability**

950V S7 or 1200V HS3 IGBT
Base-plated and base-plateless housing
Advanced die attach technology

/ **Full bidirectional power**

Fully rated current components

1500 V_{DC} PCS DC/AC Modules

flowNPC S3 split: 1200V HS IGBT NPC

Art.Nr: B0-SP12NIB300SH-PG39F08T-/7/

B0-SP12NIC300SH-PG49F08T-/7/

- / Bi-directional NPC → Fully rated diodes
- / 1200V IGBTs allow operation at 1600V_{DC} and beyond
- / Lowest commutation loop inductance → snubber less operation
- / Optimized pin layout for reduced PCB design complexity
- / Baseplate-less module for improved cost/performance



flow S3 12mm housing

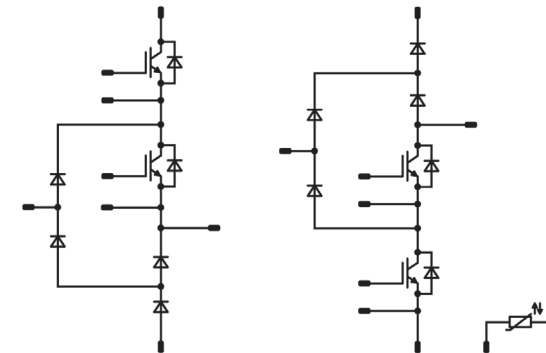

Power rating
120~150 kW
Three-phase
system

1500 V_{DC} PCS DC/AC Modules

flowANPC 2: 950 V S7+L7 ANPC

Art.Nr: 30-FT10NAA200S701-PE59F08

- / Support 1500 VDC bus
- / ANPC design to reduce the stray inductance
- / flow2 baseplate for easy thermal design
- / Easy parallel connection for power expansion
- / Highest efficiency due to 950V S7+L7

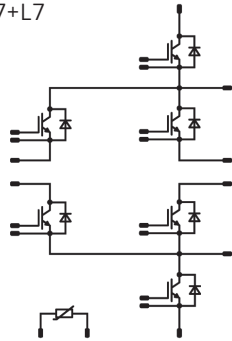
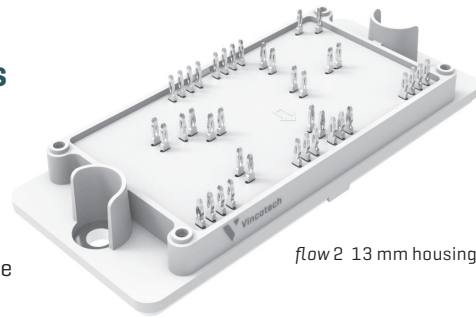

Power rating
100~150 kW
Three-phase
system

1500 V_{DC} PCS DC/AC Modules

flowPACK 1: 1200 V IGBT4-HS3

Art.Nr: 10-FY126TA075SH-L829F68

- / Support 1600Vdc and beyond
- / 2x Sixpack in series for bidirectional DC-DC
- / 2x flow1 housing for better layout and thermal design
- / Tandem diode for optimum cost/performance

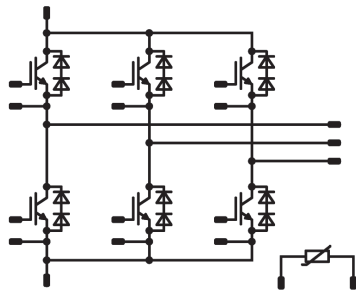
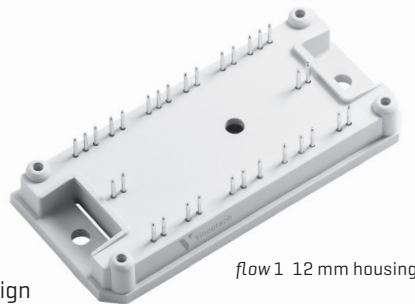

Power rating
100~150 kW
Three-phase
system

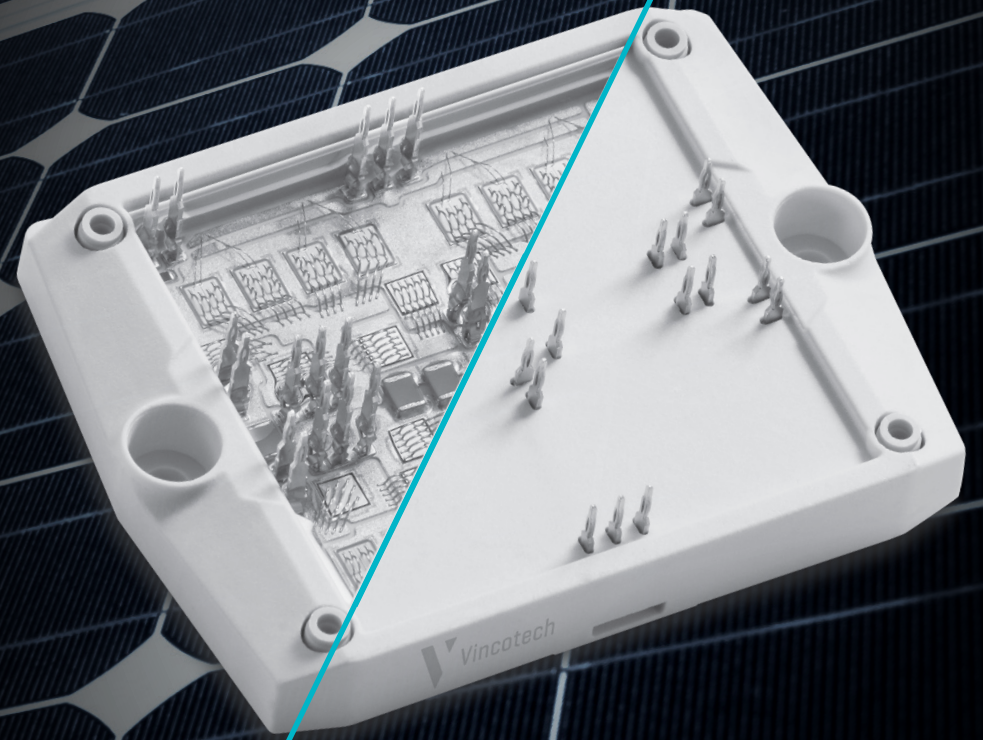

1500 V_{DC} PCS DC/DC Modules

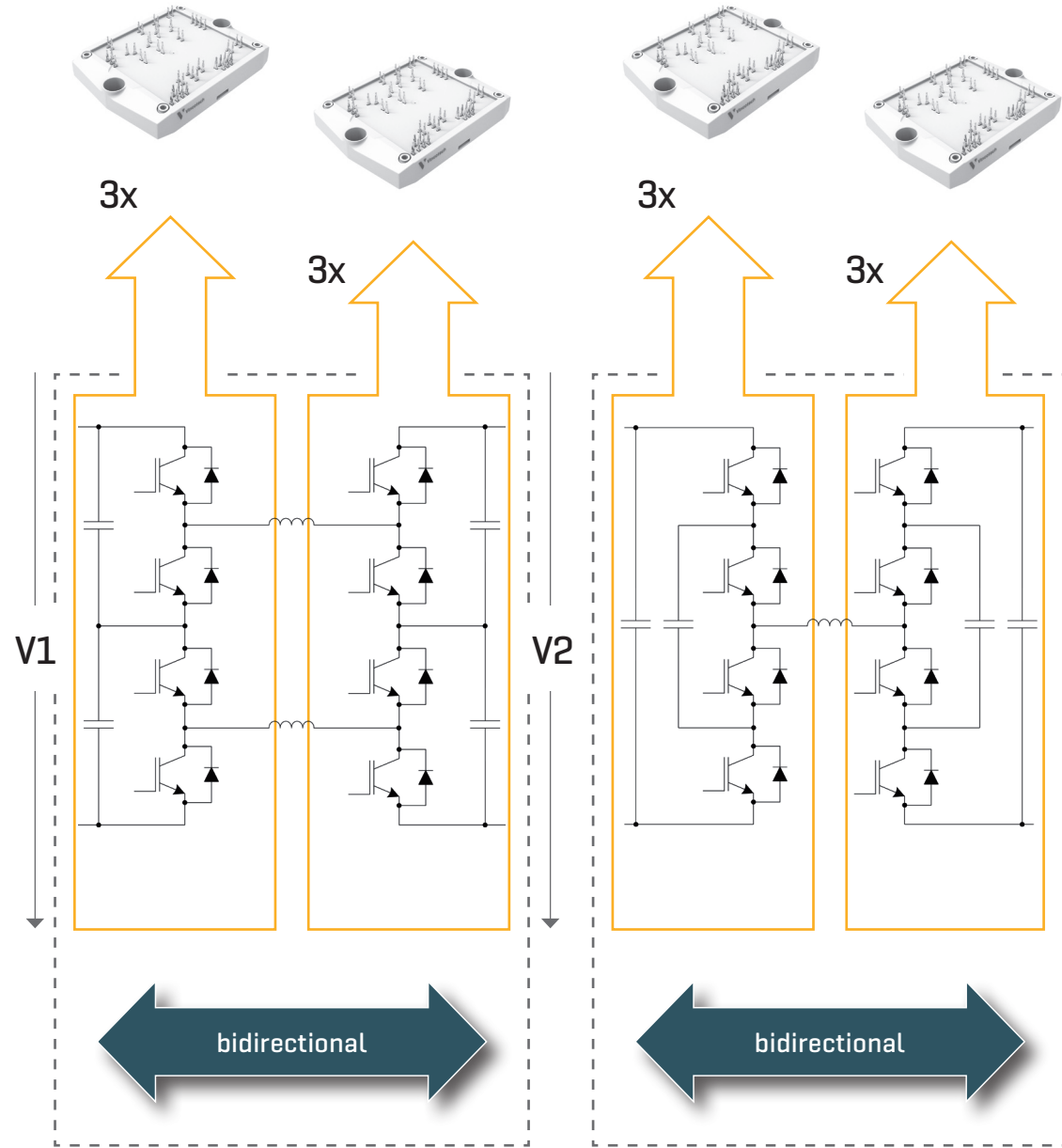

3x interleaved for higher power

Art.Nr: B0-SP10NDA100S7-LU18F08T

3x interleaved for higher power

Art.Nr: B0-SP10F3A100S7-LU49F08T

flow3xBUCK-BOOST S3

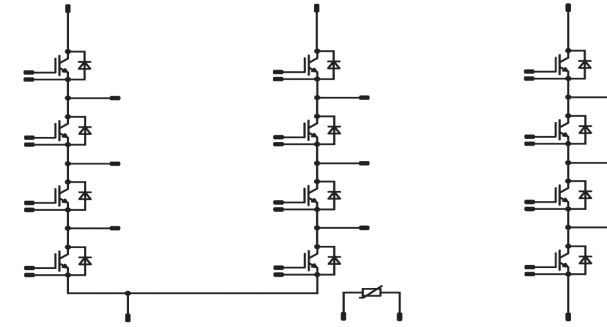

Art.Nr: B0-SP10F3A100S7-LU49F08T

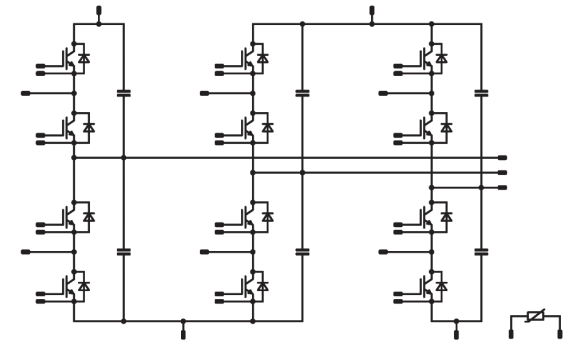

Art.Nr: B0-SP10NDA100S7-LU18F08T

Features:

- / NPC without diodes or Flying Capacitor topology
- / flow S3 baseplate-less design for improved cost/performance
- / 3x buck-boost in one housing
- / Single DCB design to reduce the stray inductance
- / High efficiency due to 950V S7

Power rating
60~80 kW
Three-phase
system



flow S3 12 mm housing



Vincotech GmbH

Biberger Strasse 93 / 82008 Unterhaching / Germany
T +49 89 878 067-0 / info@vincotech.com

www.vincotech.com