



flowPACK E1 SiC

1200 V / 80 mΩ

Topology features

- 3ph Inverter
- Low and high side Kelvin Emitter for improved switching performance
- MOSFET
- Open Emitter configuration
- Temperature sensor

Component features

- High Blocking Voltage with low drain source on state resistance
- High speed SiC-MOSFET technology
- Resistant to Latch-up

Housing features

- Base isolation: Al₂O₃
- Convex shaped substrate for superior thermal contact
- Compact housing
- CTI600 housing material
- Thermo-mechanical push-and-pull force relief
- Press-fit pin
- Reliable cold welding connection

Target applications

- Embedded Drives
- Heat Pumps
- HVAC

Types

- 10-EZ126PA080MS-LS17F78T

flow E1 12 mm housing



Schematic

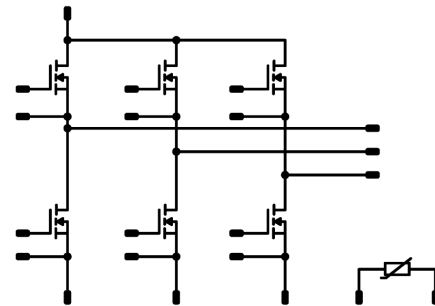



Vincotech

10-EZ126PA080MS-LS17F78T
datasheet

Maximum Ratings

$T_j = 25\text{ °C}$, unless otherwise specified

Parameter	Symbol	Conditions	Value	Unit
Inverter Switch				
Drain-source voltage	V_{DSS}		1200	V
Drain current (DC current)	I_D	$T_j = T_{jmax}$ $T_s = 80\text{ °C}$	27	A
Peak drain current	I_{DM}	t_p limited by T_{jmax}	68	A
Total power dissipation	P_{tot}	$T_j = T_{jmax}$ $T_s = 80\text{ °C}$	62	W
Gate-source voltage	V_{GSS}		0 / 18	V
		dynamic	-5 / 22	
Maximum Junction Temperature	T_{jmax}		175	°C

Module Properties

Thermal Properties

Storage temperature	T_{stg}		-40...+125	°C
Operation temperature under switching condition	T_{jop}		-40...+($T_{jmax} - 25$)	°C

Isolation Properties

Isolation voltage	V_{isol}	DC Test Voltage* $t_p = 2\text{ s}$	6000	V
Creepage distance			>12,7	mm
Clearance			8,74	mm
Comparative Tracking Index	CTI		≥ 600	

*100 % tested in production



Vincotech

10-EZ126PA080MS-LS17F78T
datasheet

Characteristic Values

Parameter	Symbol	Conditions					Values			Unit
		V_{GE} [V] V_{GS} [V]	V_{CE} [V] V_{DS} [V] V_F [V]	I_C [A] I_D [A] I_F [A]	T_j [°C]	Min	Typ	Max		

Inverter Switch

Static

Drain-source on-state resistance	$r_{DS(on)}$	18		15	25 125 150		71,7 77,2 83,7	100 ⁽¹⁾	mΩ
Gate-source threshold voltage	$V_{GS(th)}$			0,0015	25	3,6	4,6	5,6	V
Gate to Source Leakage Current	I_{GSS}	22	0		25			200	nA
Zero Gate Voltage Drain Current	I_{DSS}	0	1200		25			50	μA
Internal gate resistance	r_g						3		Ω
Short-circuit input capacitance	C_{iss}	0	10	0	25		2000		pF
Reverse transfer capacitance	C_{rss}						46		

Thermal

Thermal resistance junction to sink ⁽²⁾	$R_{th(j-s)}$	$\lambda_{paste} = 3,4$ W/mK (PSX)					1,53		K/W
--	---------------	---------------------------------------	--	--	--	--	------	--	-----



Vincotech

10-EZ126PA080MS-LS17F78T
datasheet

Characteristic Values

Parameter	Symbol	Conditions					Values			Unit
		V_{GE} [V] V_{GS} [V]	V_{CE} [V] V_{DS} [V] V_F [V]	I_C [A] I_D [A] I_F [A]	T_j [°C]	Min	Typ	Max		
Dynamic										
Turn-on delay time	$t_{d(on)}$	$R_{gon} = 4 \Omega$ $R_{goff} = 4 \Omega$	0/18	600	16	25		17,72		ns
						125		15,56		
						150		15,75		
Rise time	t_r					25		7,65		
						125		6,97		ns
						150		6,68		
Turn-off delay time	$t_{d(off)}$					25		44,04		
						125		51,06		ns
						150		53,66		
Fall time	t_f					25		18,63		
						125		24,96		ns
						150		25,76		
Turn-on energy (per pulse)	E_{on}	$Q_{rFWD}=0,096 \mu C$ $Q_{rFWD}=0,237 \mu C$ $Q_{rFWD}=0,29 \mu C$				25		0,234		mWs
						125		0,223		
						150		0,233		
Turn-off energy (per pulse)	E_{off}					25		0,059		mWs
						125		0,059		
						150		0,059		
Peak recovery current	I_{RRM}					25		14,11		A
						125		18,26		
						150		20,6		
Reverse recovery time	t_{rr}					25		12,2		ns
						125		27,46		
						150		27,04		
Recovered charge	Q_r	$di/dt=2162 A/\mu s$ $di/dt=2703 A/\mu s$ $di/dt=2694 A/\mu s$				25		0,096		μC
						125		0,237		
						150		0,29		
Reverse recovered energy	E_{rec}					25		0,014		mWs
						125		0,072		
						150		0,083		
Peak rate of fall of recovery current	$(di_{rr}/dt)_{max}$					25		3572,19		A/ μs
						125		2220,85		
						150		1407,8		



Vincotech

Characteristic Values

Parameter	Symbol	Conditions					Values			Unit
		V_{GS} [V]	V_{GE} [V]	V_{DS} [V]	V_{CE} [V]	T_j [°C]	Min	Typ	Max	

Thermistor

Static

Rated resistance	R					25		5		kΩ
Deviation of R100	$A_{R/R}$	$R_{100} = 499 \Omega$				100	3,2		3,3	%
Power dissipation	P					25		130		mW
Power dissipation constant	d					25		1,3		mW/K
B-value	$B_{(25/50)}$	Tol. $\pm 1 \%$						3380		K
Vincotech Thermistor Reference									V	

⁽¹⁾ Value at chip level

⁽²⁾ Only valid with pre-applied Vincotech thermal interface material.



Inverter Switch Characteristics

figure 1. MOSFET

Typical output characteristics
 $I_D = f(V_{DS})$

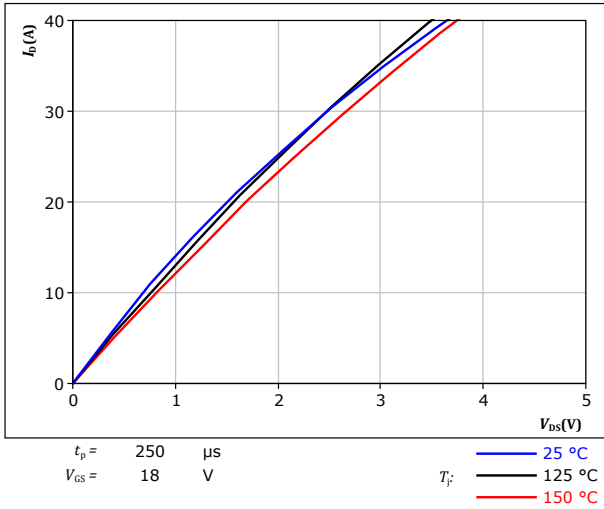

figure 2. MOSFET

Typical output characteristics
 $I_D = f(V_{DS})$

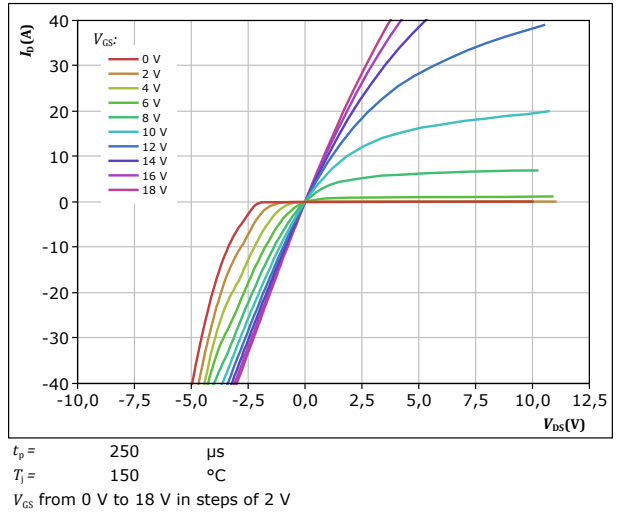

figure 3. MOSFET

Typical transfer characteristics
 $I_D = f(V_{GS})$

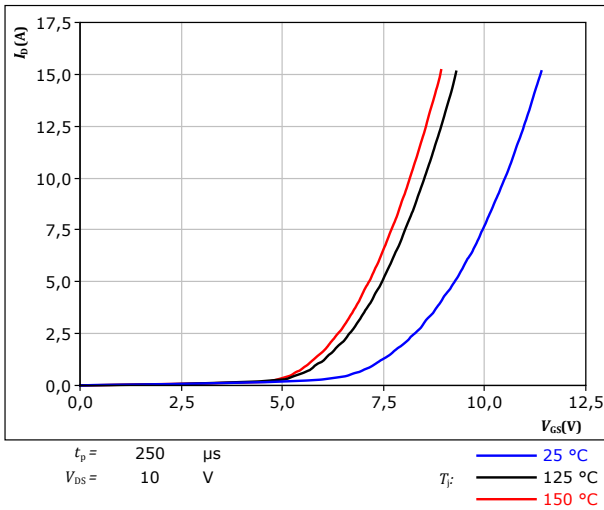
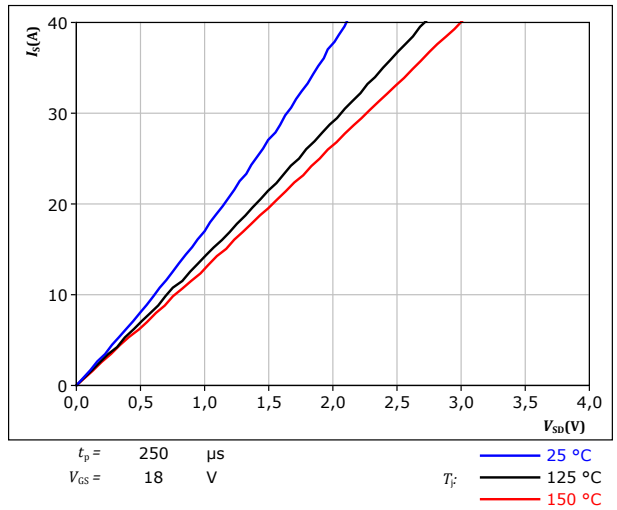

figure 4. MOSFET

Typical reverse drain current characteristics
 $I_{SD} = f(V_{SD})$





Inverter Switch Characteristics

figure 5. MOSFET

Transient thermal impedance as a function of pulse width

$$Z_{th(j-c)} = f(t_p)$$

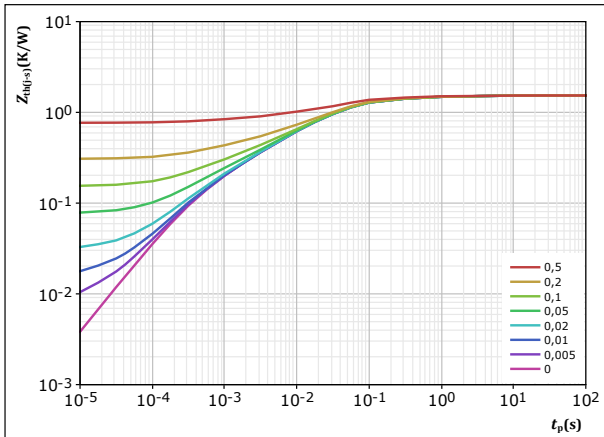

$$D = \frac{t_p}{T}$$

$$R_{th(j-c)} = 1,534 \text{ K/W}$$

MOSFET thermal model values

R (K/W)	τ (s)
6,63E-02	3,08E+00
2,43E-01	2,20E-01
8,25E-01	3,12E-02
2,87E-01	3,59E-03
1,12E-01	4,04E-04

figure 6. MOSFET

Safe operating area

$$I_D = f(V_{DS})$$

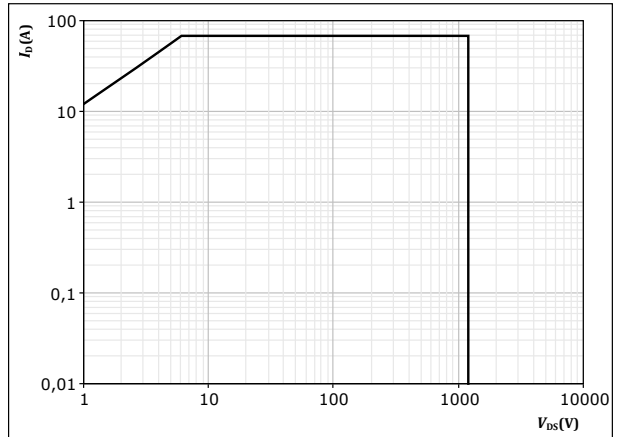

D = single pulse

$$T_s = 80 \text{ } ^\circ\text{C}$$

$$V_{GS} = 18 \text{ V}$$

$$T_1 = T_{jmax}$$



Thermistor Characteristics

figure 7. Thermistor

Typical NTC characteristic as function of temperature

$$R_T = f(T)$$

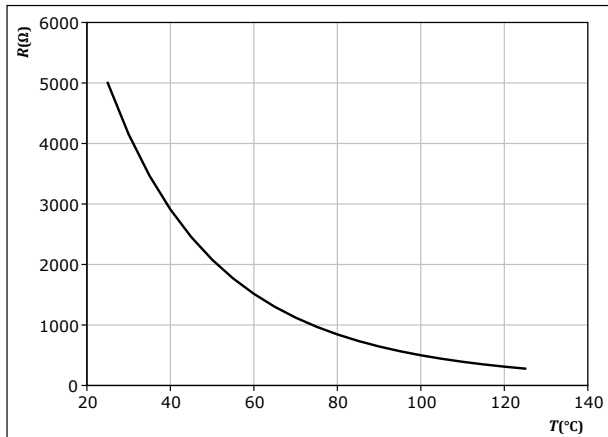



Inverter Switching Characteristics

figure 8. MOSFET

Typical switching energy losses as a function of drain current
 $E = f(I_D)$

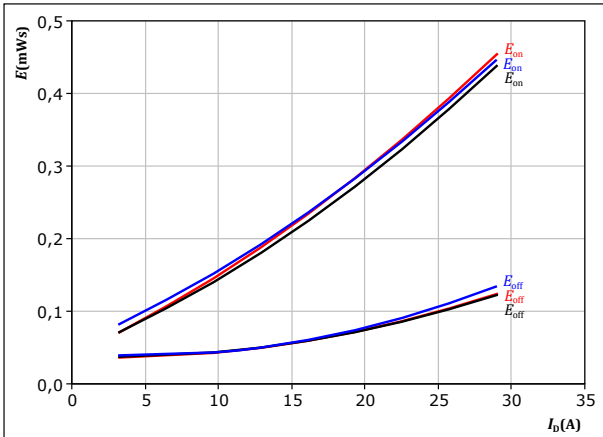

With an inductive load at
 $V_{DS} = 600 \text{ V}$
 $V_{GS} = 0/18 \text{ V}$
 $R_{gon} = 4 \text{ } \Omega$
 $R_{goff} = 4 \text{ } \Omega$

T_j : 25 °C (blue), 125 °C (black), 150 °C (red)

figure 9. MOSFET

Typical switching energy losses as a function of MOSFET turn on gate resistor
 $E = f(R_g)$

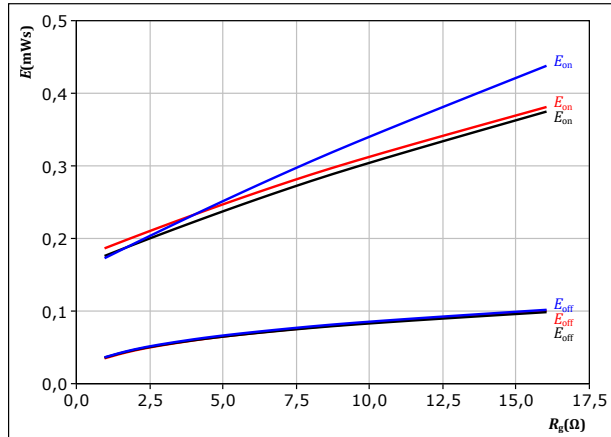

With an inductive load at
 $V_{DS} = 600 \text{ V}$
 $V_{GS} = 0/18 \text{ V}$
 $I_D = 16 \text{ A}$

T_j : 25 °C (blue), 125 °C (black), 150 °C (red)

figure 10. MOSFET

Typical reverse recovered energy loss as a function of drain current
 $E_{rec} = f(I_D)$

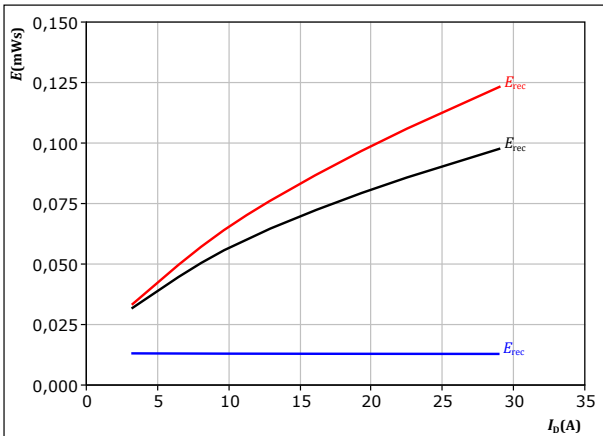

With an inductive load at
 $V_{DS} = 600 \text{ V}$
 $V_{GS} = 0/18 \text{ V}$
 $R_{gon} = 4 \text{ } \Omega$

T_j : 25 °C (blue), 125 °C (black), 150 °C (red)

figure 11. MOSFET

Typical reverse recovered energy loss as a function of MOSFET turn on gate resistor
 $E_{rec} = f(R_g)$

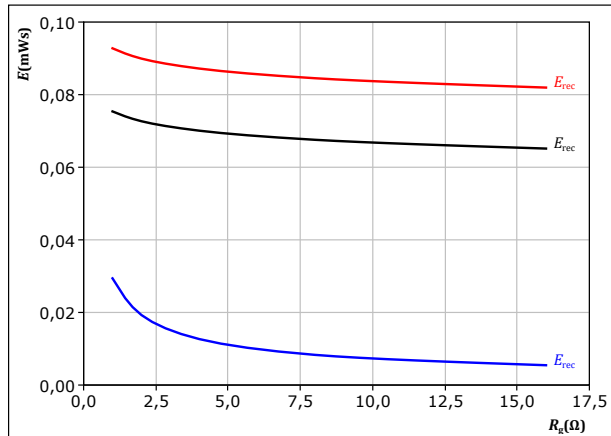

With an inductive load at
 $V_{DS} = 600 \text{ V}$
 $V_{GS} = 0/18 \text{ V}$
 $I_D = 16 \text{ A}$

T_j : 25 °C (blue), 125 °C (black), 150 °C (red)



Inverter Switching Characteristics

figure 12. MOSFET

Typical switching times as a function of drain current
 $t = f(I_D)$

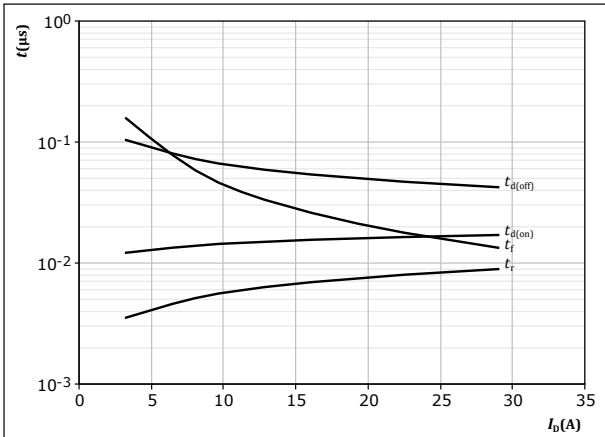

With an inductive load at
 $T_j = 150 \text{ }^\circ\text{C}$
 $V_{DS} = 600 \text{ V}$
 $V_{GS} = 0/18 \text{ V}$
 $R_{g(on)} = 4 \text{ } \Omega$
 $R_{g(off)} = 4 \text{ } \Omega$

figure 13. MOSFET

Typical switching times as a function of MOSFET turn on gate resistor
 $t = f(R_g)$

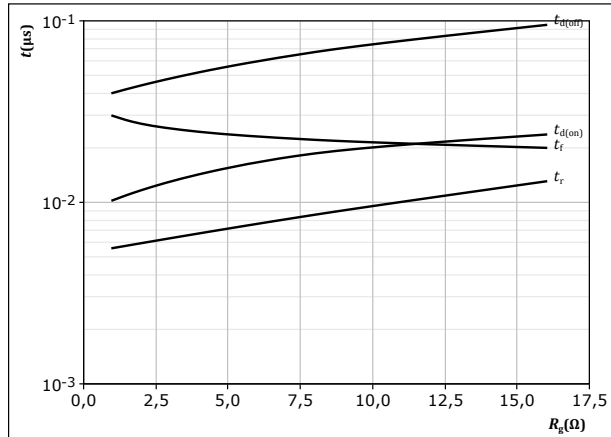

With an inductive load at
 $T_j = 150 \text{ }^\circ\text{C}$
 $V_{DS} = 600 \text{ V}$
 $V_{GS} = 0/18 \text{ V}$
 $I_D = 16 \text{ A}$

figure 14. MOSFET

Typical reverse recovery time as a function of drain current
 $t_{rr} = f(I_D)$

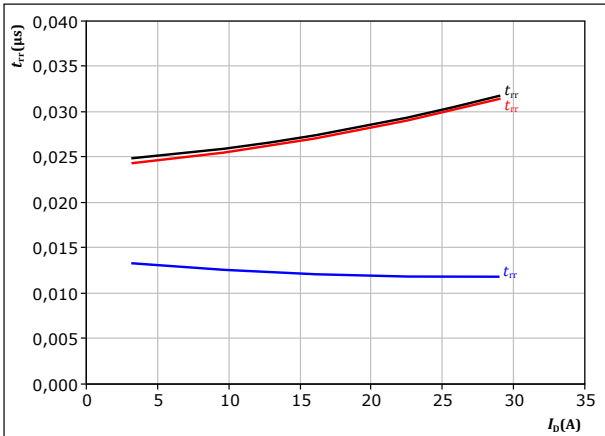

At $V_{DS} = 600 \text{ V}$
 $V_{GS} = 0/18 \text{ V}$
 $R_{g(on)} = 4 \text{ } \Omega$
 $T_j:$ — 25 °C
— 125 °C
— 150 °C

figure 15. MOSFET

Typical reverse recovery time as a function of MOSFET turn on gate resistor
 $t_{rr} = f(R_{g(on)})$

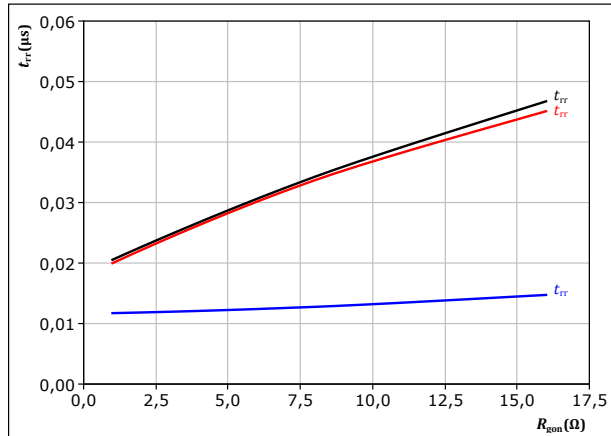

At $V_{DS} = 600 \text{ V}$
 $V_{GS} = 0/18 \text{ V}$
 $I_D = 16 \text{ A}$
 $T_j:$ — 25 °C
— 125 °C
— 150 °C



Inverter Switching Characteristics

figure 16. MOSFET

Typical recovered charge as a function of drain current

$$Q_r = f(I_D)$$

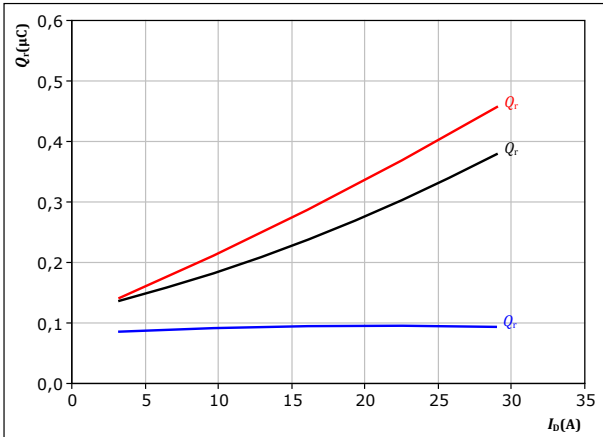

At $V_{DS} = 600$ V
 $V_{GS} = 0/18$ V
 $R_{gon} = 4$ Ω

T_j : — 25 °C
 — 125 °C
 — 150 °C

figure 17. MOSFET

Typical recovered charge as a function of MOSFET turn on gate resistor

$$Q_r = f(R_{gon})$$

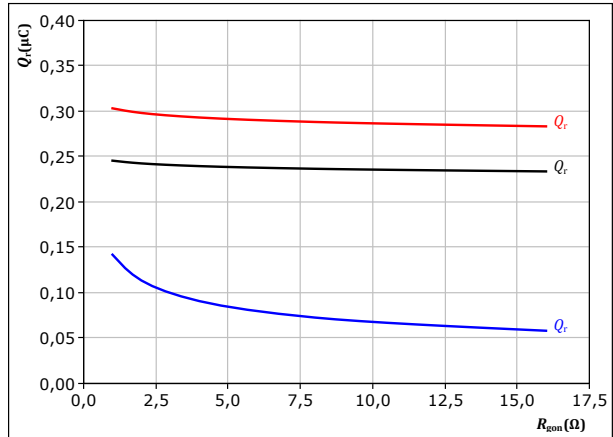

At $V_{DS} = 600$ V
 $V_{GS} = 0/18$ V
 $I_D = 16$ A

T_j : — 25 °C
 — 125 °C
 — 150 °C

figure 18. MOSFET

Typical peak reverse recovery current as a function of drain current

$$I_{RM} = f(I_D)$$

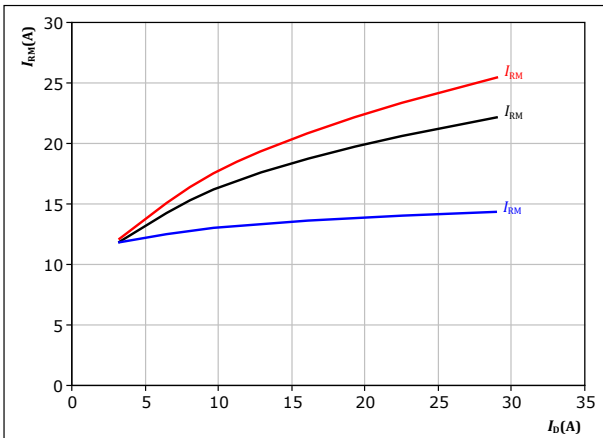

At $V_{DS} = 600$ V
 $V_{GS} = 0/18$ V
 $R_{gon} = 4$ Ω

T_j : — 25 °C
 — 125 °C
 — 150 °C

figure 19. MOSFET

Typical peak reverse recovery current as a function of MOSFET turn on gate resistor

$$I_{RM} = f(R_{gon})$$

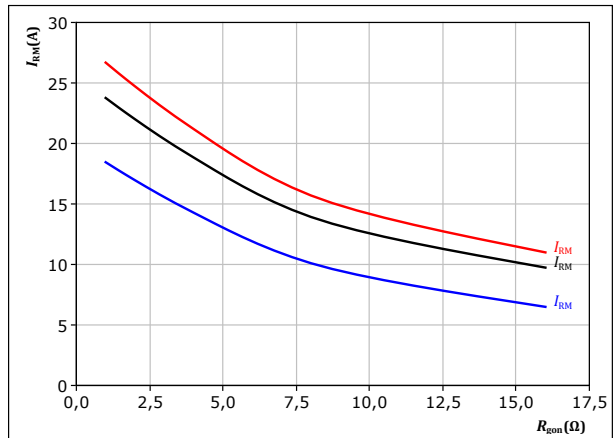

At $V_{DS} = 600$ V
 $V_{GS} = 0/18$ V
 $I_D = 16$ A

T_j : — 25 °C
 — 125 °C
 — 150 °C



Inverter Switching Characteristics

figure 20. MOSFET

Typical rate of fall of forward and reverse recovery current as a function of drain current
 $di_f/dt, di_{rr}/dt = f(I_D)$

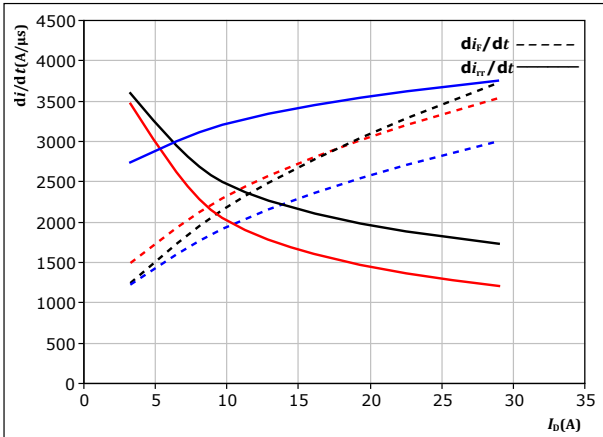

At $V_{DS} = 600$ V
 $V_{GS} = 0/18$ V
 $R_{g(on)} = 4$ Ω
 $T_j = 25$ °C
 $T_j = 125$ °C
 $T_j = 150$ °C

figure 21. MOSFET

Typical rate of fall of forward and reverse recovery current as a function of turn on gate resistor
 $di_f/dt, di_{rr}/dt = f(R_{g(on)})$

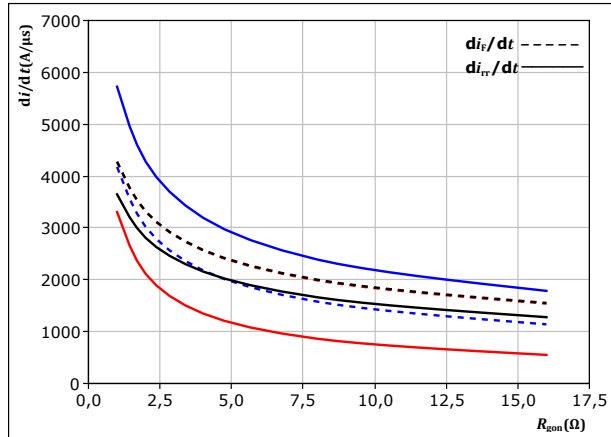

At $V_{DS} = 600$ V
 $V_{GS} = 0/18$ V
 $I_D = 16$ A
 $T_j = 25$ °C
 $T_j = 125$ °C
 $T_j = 150$ °C

figure 22. MOSFET

Reverse bias safe operating area

$I_D = f(V_{DS})$

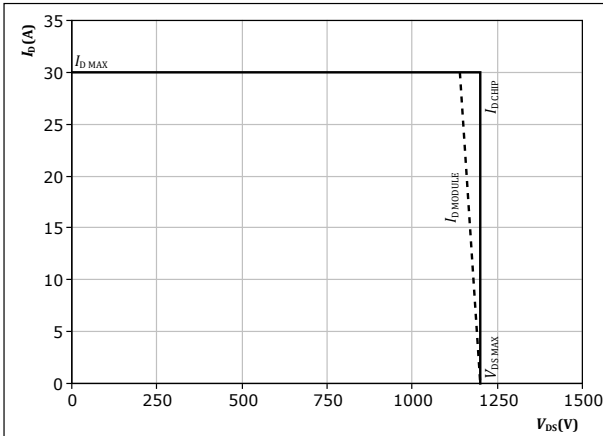

At $T_j = 150$ °C
 $R_{g(on)} = 4$ Ω
 $R_{g(off)} = 4$ Ω



Inverter Switching Definitions

figure 23. MOSFET

Turn-off Switching Waveforms & definition of t_{doff} t_{Eoff} (t_{Eoff} = integrating time for E_{off})

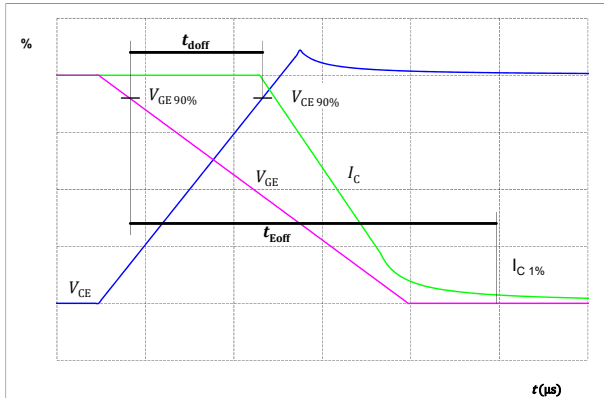

figure 24. MOSFET

Turn-on Switching Waveforms & definition of t_{don} t_{Eon} (t_{Eon} = integrating time for E_{on})

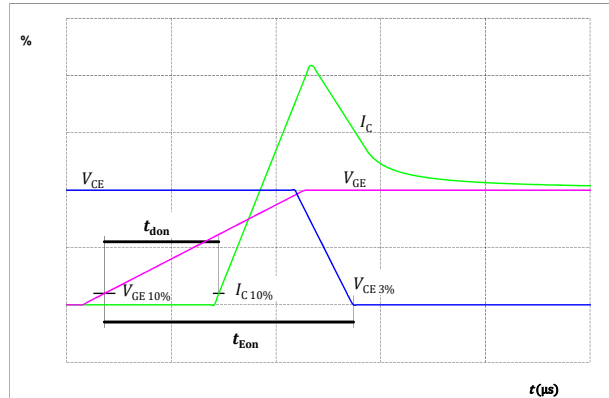

figure 25. MOSFET

Turn-off Switching Waveforms & definition of t_f

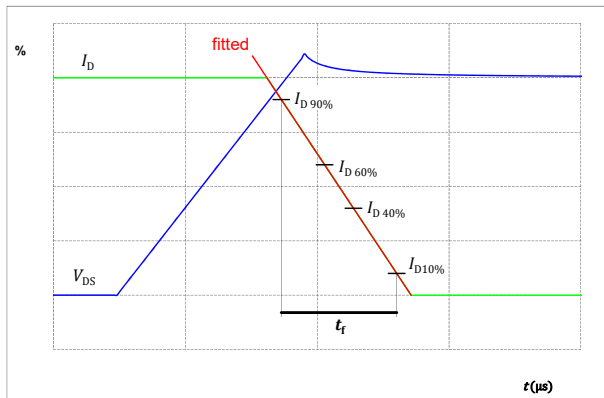
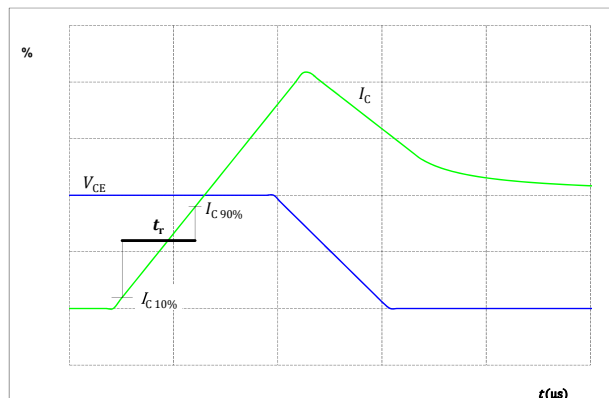

figure 26. MOSFET

Turn-on Switching Waveforms & definition of t_r





Inverter Switching Definitions

figure 27. FWD

Turn-off Switching Waveforms & definition of t_{tr}

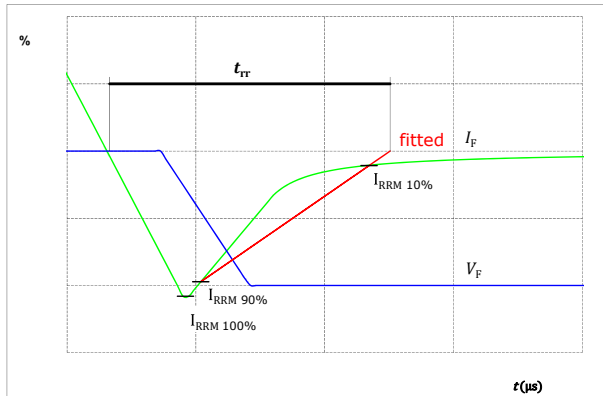

figure 28. FWD

Turn-on Switching Waveforms & definition of t_{Qr} (t_{Qr} = integrating time for Q_r)

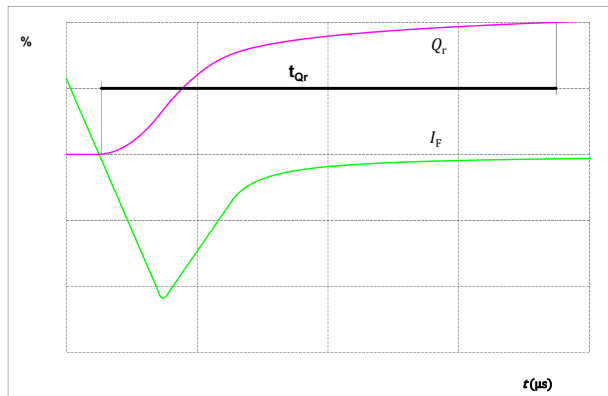
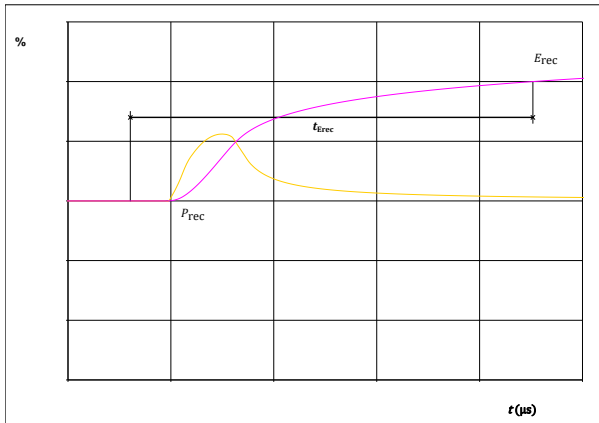

figure 29. FWD

Turn-on Switching Waveforms & definition of t_{Erec} (t_{Erec} = integrating time for E_{rec})





Vincotech

Ordering Code	
Version	Ordering Code
Without thermal paste	10-EZ126PA080MS-LS17F78T
With thermal paste (3,4 W/mK, PSX-P7)	10-EZ126PA080MS-LS17F78T-/3/

Marking						
	Text	Name	Date code	UL & VIN	Lot	Serial
		NN-NNNNNNNNNNNNNNN- TTTTTV TTTTTV	WWYY	UL VIN	LLLLL	SSSS
Datamatrix	Type&Ver	Lot number	Serial	Date code		
	TTTTTTTV	LLLLL	SSSS	WWYY		

Pin table [mm]				Outline	
Pin	X	Y	Function	<p>center of press-fit pin head pin head type "T" PCB plated through-hole $\varnothing 1$ mm $+0.09$ / -0.06 for further PCB design rules refer to the latest handling instruction</p> <p>Tolerance of position: ± 0.4 mm at the end of pins Dimension of coordinate axis is only offset without tolerance</p>	
1	32	0	G15		
2	28,8	0	S15		
3	19,2	0	G13		
4	16	0	S13		
5	3,2	0	S11		
6	0	0	G11		
7	32	6,4	Ph3		
8	19,2	6,4	Ph2		
9	0	6,4	Ph1		
10	32	12,8	DC-3		
11	19,2	12,8	DC-2		
12	0	12,8	DC-1		
13	28,8	19,2	DC+		
14	19,2	19,2	DC+		
15	9,6	19,2	DC+		
16	32	25,6	Therm2		
17	28,8	25,6	Therm1		
18	22,4	25,6	G16		
19	19,2	25,6	S16		
20	12,8	25,6	G14		
21	9,6	25,6	S14		
22	3,2	25,6	G12		
23	0	25,6	S12		



Vincotech

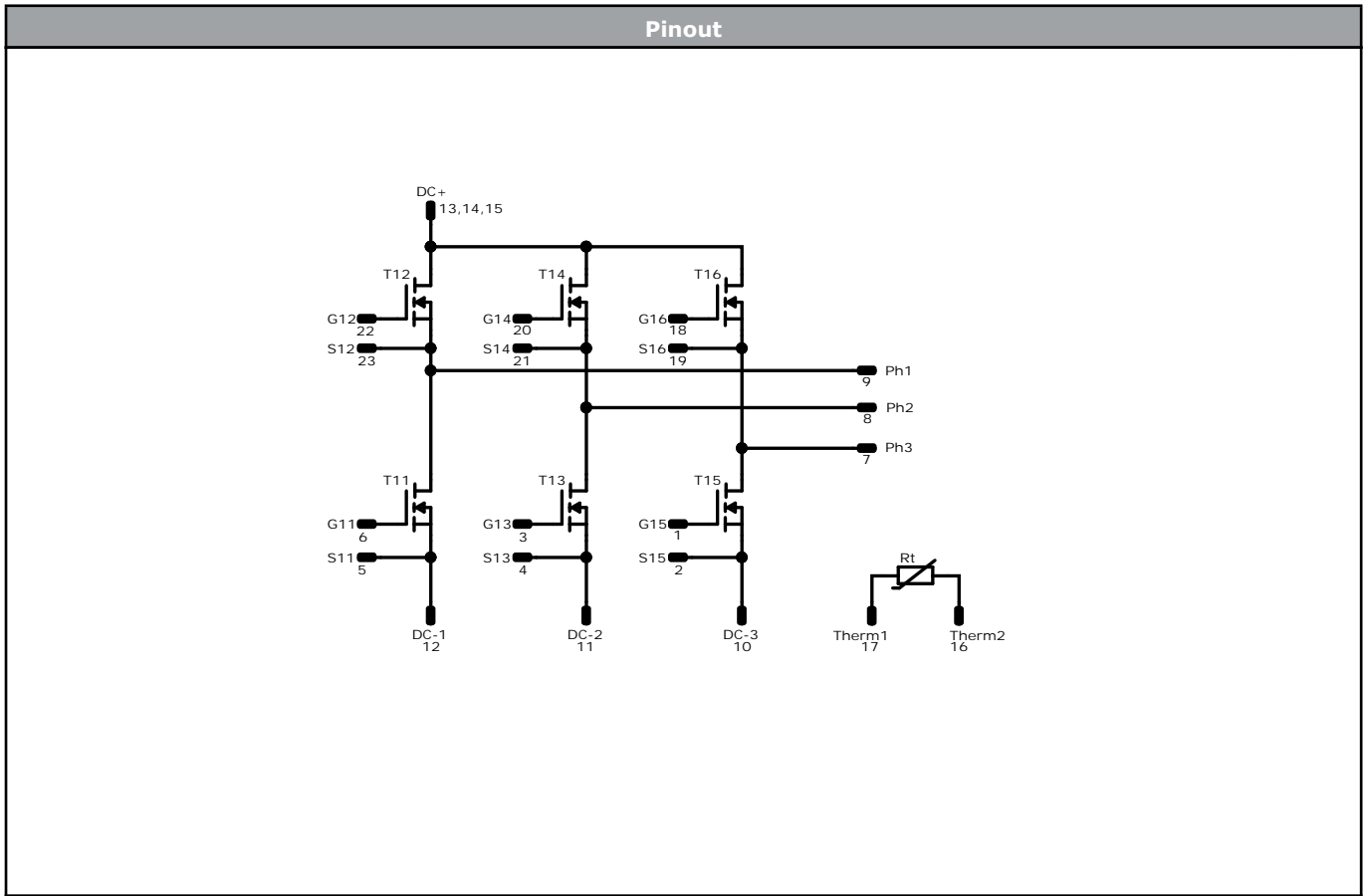

Identification					
ID	Component	Voltage	Current	Function	Comment
T11, T12, T13, T14, T15, T16	MOSFET	1200 V	80 mΩ	Inverter Switch	
Rt	Thermistor			Thermistor	



Packaging instruction				
Standard packaging quantity (SPQ) 100	>SPQ	Standard	<SPQ	Sample

Handling instruction
Handling instructions for <i>flow</i> E1 packages see vincotech.com website.

Package data
Package data for <i>flow</i> E1 packages see vincotech.com website.

Vincotech thermistor reference
See Vincotech thermistor reference table at vincotech.com website.

UL recognition and file number
This device is UL 1557 recognized under E192116 up to a junction temperature under switching condition $T_{j,op}=175^{\circ}C$ and up to 3500VAC/1min isolation voltage. For more information see vincotech.com website.



Document No.:	Date:	Modification:	Pages
10-EZ126PA080MS-LS17F78T-D1-14	1 Mar. 2024	Initial Release	

DISCLAIMER

The information, specifications, procedures, methods and recommendations herein (together "information") are presented by Vincotech to reader in good faith, are believed to be accurate and reliable, but may well be incomplete and/or not applicable to all conditions or situations that may exist or occur. Vincotech reserves the right to make any changes without further notice to any products to improve reliability, function or design. No representation, guarantee or warranty is made to reader as to the accuracy, reliability or completeness of said information or that the application or use of any of the same will avoid hazards, accidents, losses, damages or injury of any kind to persons or property or that the same will not infringe third parties rights or give desired results. It is reader's sole responsibility to test and determine the suitability of the information and the product for reader's intended use.

LIFE SUPPORT POLICY

Vincotech products are not authorised for use as critical components in life support devices or systems without the express written approval of Vincotech.

As used herein:

1. Life support devices or systems are devices or systems which, (a) are intended for surgical implant into the body, or (b) support or sustain life, or (c) whose failure to perform when properly used in accordance with instructions for use provided in labelling can be reasonably expected to result in significant injury to the user.
2. A critical component is any component of a life support device or system whose failure to perform can be reasonably expected to cause the failure of the life support device or system, or to affect its safety or effectiveness.