

Handling Instructions

for *flow* E3BP packages

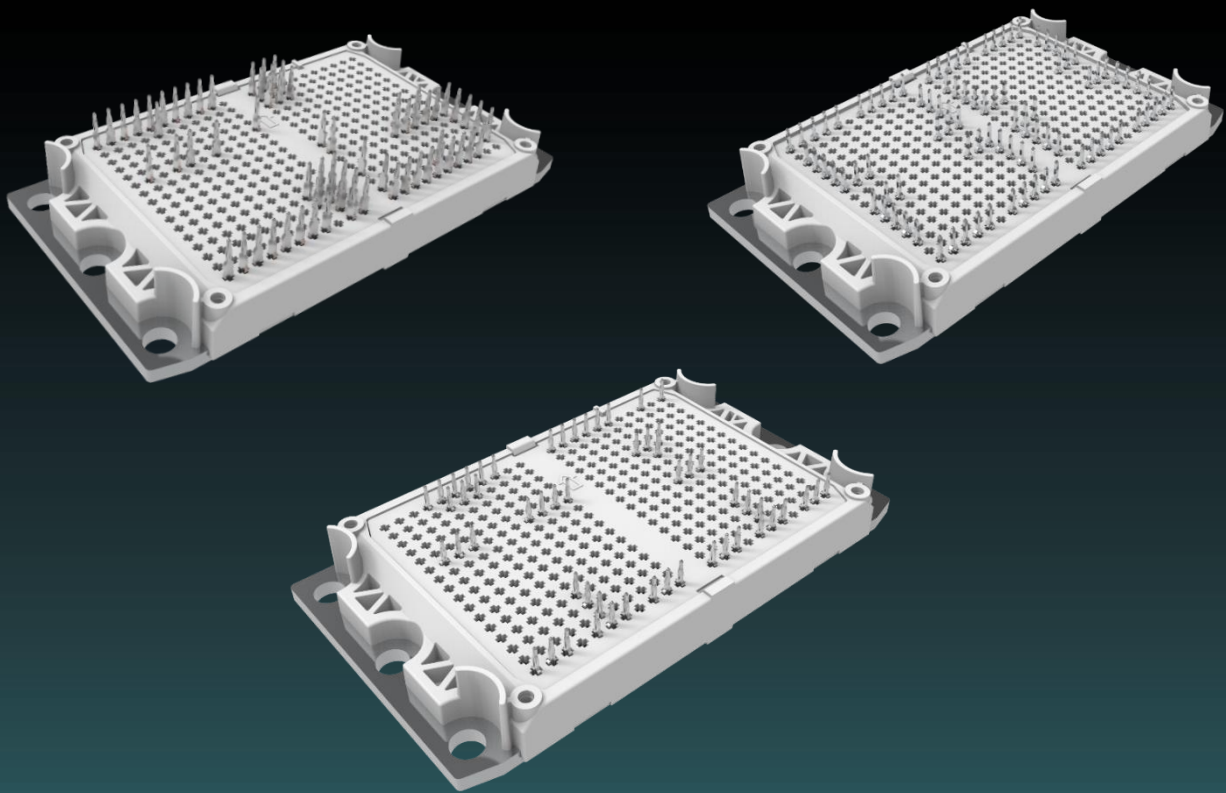

Vincotech



This document is valid for all type of flow E3BP modules

Date: 14.11.2024

Revision:

Created by: Zs. Gyimóthy

Rev. 01

Proprietary data, company confidential. All rights reserved.

Handling Instructions

for *flow* E3BP packages



Vincotech

1	General instructions	6
2	Specification for PCBs.....	7
2.1	Specifications for modules with Press-fit pins	7
2.2	Specification for modules with solder pins.....	9
2.3	Specification for modules with Press-fit pins that are soldered to the PCB	10
2.4	Required PCB cutouts for plastic housing and screws.....	10
2.5	Recommended PCB-thicknesses and mounting heights	11
2.5.1	Solder pin type modules	12
2.5.2	Press-fit pin type modules	13
3	Specification for baseplate	14
4	Specification for heat sinks	16
5	Specification for thermal interface materials (TIM)	16
5.1	Modules with qualified thermal grease	16
5.2	Modules with qualified phase change material (PCM) ... Error! Bookmark not defined.	
5.2.1	Modules are available also with pre-applied PCM.....	16
5.3	Application of TIM.....	16
6	Specification for fastening screws to the heat sink	17
6.1	Screw with pre-assembled washers.....	18
6.2	Mounting with automatic screwdriver	19
7	Press in process of modules with Press-fit pins	20
7.1	Press-in construction.....	20
7.1.1	Press-in top tool	21
7.1.2	Support tool.....	23
7.2	Press-in process parameters	24
7.2.1	The basic requirement for the press-in process.....	24
7.3	Process control parameters	24
8	Press-out process for modules with Press-fit pins.....	26
8.1	Press-out tool.....	27
8.2	Press-out process characteristics	27
8.3	Disassembling by hand.....	28
9	Mounting of modules with solder pins.....	28
9.1	12 mm modules	28
9.1.1	Using screws to fix the module to the PCB	28
9.1.2	Using soldering jig (without using screws)	29
9.2	15 mm modules	29
9.2.1	Using soldering jig only	29

Handling Instructions

for *flow* E3BP packages



Vincotech

10	Recommendation for soldering	30
10.1	Solderability specification	30
10.2	Wave soldering of modules with solder pins	31
10.3	Hand soldering parameters	31
11	ESD protection	32
12	Environmental conditions.....	32
12.1	Parameters of environment classes	32
12.1.1	Climatic conditions.....	32
12.1.2	Biological conditions.....	33
12.1.3	Chemically active substances	33
12.1.4	Mechanically active substances.....	34
12.1.5	Mechanical Conditions	34
13	Handling of trays	36
14	Disclaimer	36

Handling Instructions

for *flow* E3BP packages



Vincotech

Table of Figures

Figure 1: Module with PCB and heat sink	6
Figure 2: Specifications for 'T' type Press-fit pin	7
Figure 4: Copper visible on Press-fit pins	9
Figure 5: Solder pin diameter	9
Figure 6: PCB cutouts for 12 mm type module	10
Figure 7: PCB cutouts for 15 mm type module	11
Figure 8: Mounting height for solder pin type module	12
Figure 9: Mounting height and PCB thickness for Press-fit pin type module	13
Figure 10: Scratch dimensions	14
Figure 11: Polished baseplate	15
Figure 12: Discoloration of baseplate	15
Figure 13: Fingerprint on the baseplate	15
Figure 14: Honeycomb pattern	17
Figure 15: Screw positions in sequence	18
Figure 16: Recommended torque and speed curve	19
Figure 17: Recommended construction for the press-in process	20
Figure 18: Recommended press-in tool for modules without thermal interface material	21
Figure 19: Recommended press-in tool for modules with thermal interface material	22
Figure 20: The recommended hole and cutout dimensions for support tool	23
Figure 21: Press-in depth in PCB	24
Figure 22: Typical press-in diagram of a 20 pin module	25
Figure 23: Recommended construction for the press-out process	26
Figure 24: Force-path diagram of the press-out process	27
Figure 25: Cutting edge	28
Figure 26: Assembly illustration	29
Figure 27: Plated through hole, good soldering	30
Figure 28: Examples of discolored solder pins	30
Figure 29: Typical profile for wave soldering	31
Figure 30: Layer of trays	36

Handling Instructions

for *flow* E3BP packages



Vincotech

Revision History

Date	Revision Level	Description	Page Number(s)
14.11.2024	01	New document	

Handling Instructions

for *flow* E3BP packages



Vincotech

1 General instructions

The *flow* E3BP type modules have to be mounted to a PCB. The electrical connections between module and PCB can be made by soldering or by Press-fit technology. In applications where the module is attached to a heat sink, the PCB must also be attached to this heat sink. Figure 1 shows how this attachment can be achieved with threaded spacers.

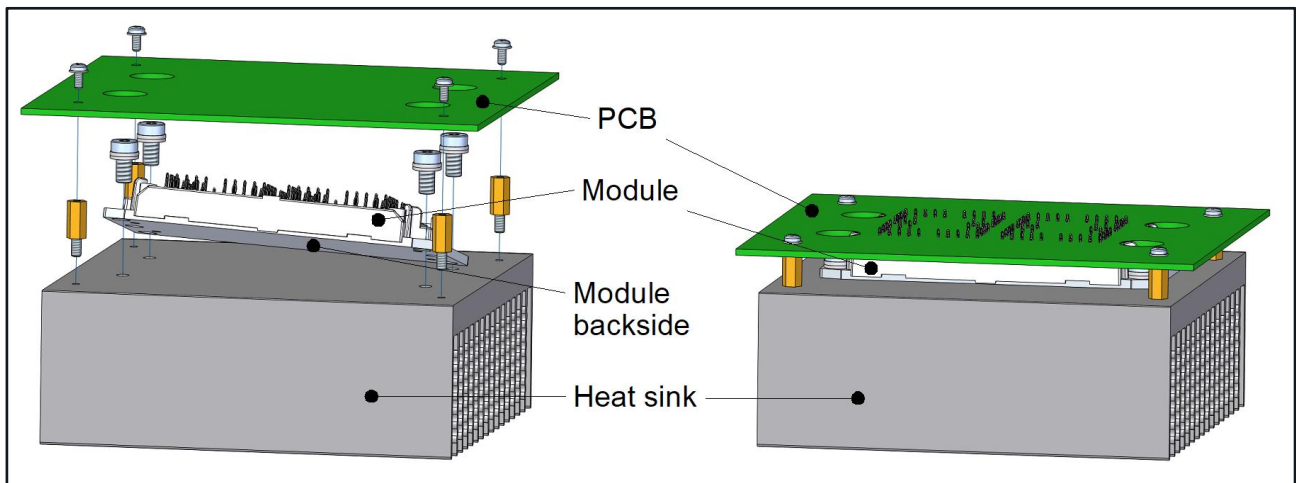

Figure 1: Module with PCB and heat sink

The distance between the top surface of the heat sink and the bottom plane of the PCB is defined by the module type, which can be 12 mm or 15 mm. PCB spacers can be used to obtain the correct spacing. The number and the position of the fixing points depend on the design of the circuit, the location of different components like capacitors or inductors and the environment of the system. General recommendation cannot be given. The recommended heights of these spacers can be seen in Section 2.5, depending on the module's parameter.

During the assembly process, a single pin is not allowed to be drawn or pushed more than ± 0.2 mm or loaded with a force greater than 35 N (except during pressing-in of Press-fit pins). The special design of the Press-fit pins prevents higher than 0.1 mm deformation of pins during pressing-in process.

The tension of the pin must not exceed ± 5 N at a maximum substrate temperature of 100°C.

Handling Instructions

for *flow* E3BP packages



Vincotech

2 Specification for PCBs

- Printed board material meets the requirements of IEC 61249-2-7.
- The maximum number of conductive layers is not limited.

2.1 Specifications for modules with Press-fit pins

- Printed board thickness must not be less than 1.6 mm (thinner PCBs require additional testing and will be performed upon request).
- PCB should be covered with solder mask on both sides.

Plated-through-hole specification	
	<i>flow</i> E3BP with Press-fit pin type 'T'
Hole drill diameter	Ø1.15 ±0.025 mm
Copper thickness in wall	>25 µm
Metallization in hole	<50 µm
PTH hole diameter	Ø 1 +0.09 / -0.06 mm
Minimum Cu width of the annular ring	> 0.1 mm
Hole position accuracy	± 0.04 mm

Press-fit pin: Type 'T'

Figure 2: Specifications for 'T' type Press-fit pin

The pin type identifier 'T' can be observed in the product part number.

Example:

30- PT 12 B2 A 200 H7 03-PK89L08 T - /7

Handling Instructions

for *flow* E3BP packages



Vincotech

- Plating material:

1. for chemical tin plating (Sn): 0.5 μm to 10 μm

The PCB can be disassembled and reused 2 more times. Upon further reuse of PCB, module has to be soldered after press-in.

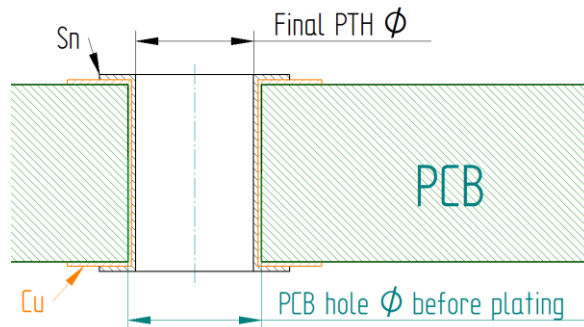

2. for HAL tin plating (Sn): 0.5 μm to 50 μm

The PCB can be disassembled and reused 2 more times. Upon further reuse of PCB, module has to be soldered after press-in.

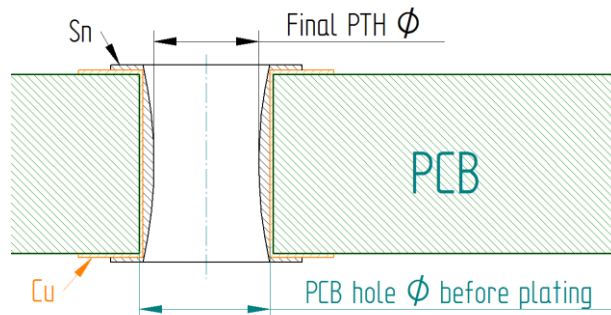

3. gold (Au): not generally released

Individual release of PCB system is required.

Upon any further reuse of PCB with Au the module has to be soldered after press-in.

Figure 3: Plating specifications (for illustration only, no real proportions)

- Minimum distance between the edge of the PCB and the centre of the pin hole: 4 mm
- Minimum distance between the centre of the pin hole and the component on the PCB: 4 mm
- For any other requirements IEC 60352-5 2008 standard should be considered

Handling Instructions

for *flow* E3BP packages



Vincotech

- The Press-fit pins of *flow* E3BP modules are plated with continuous tin finish and nickel underlayer to promote Press-fit function and solderability. Due to process and storage conditions the copper may become visible on the bottom of the pin up to the green line indicated on the picture (Figure 4: Copper visible on Press-fit pins). This is merely a cosmetic imperfection and does not influence the Press-fit function or solderability of pins as it does not affect the plating quality of the head of the pin.

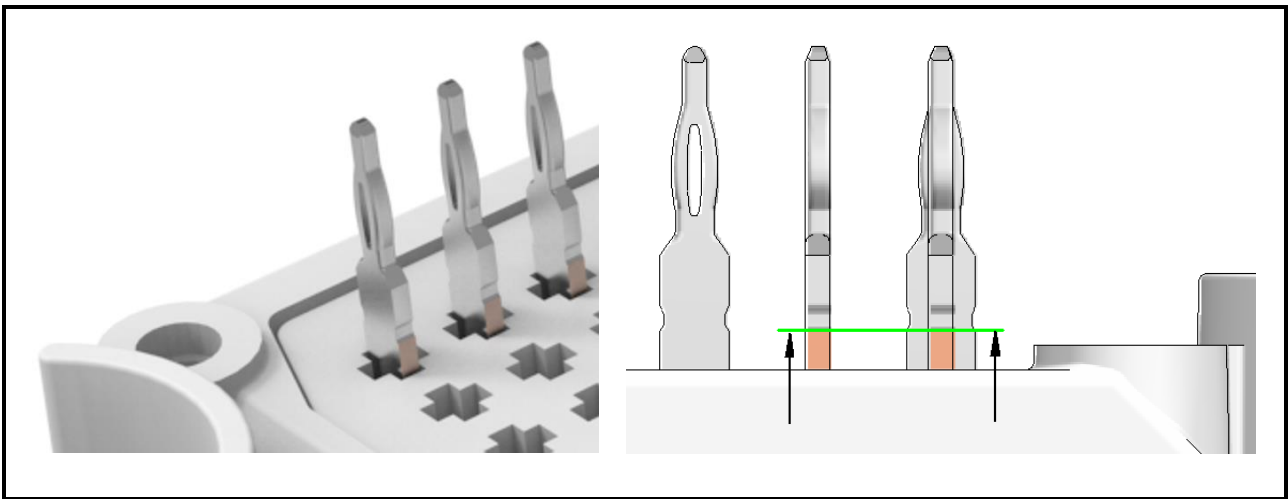

Figure 4: Copper visible on Press-fit pins

2.2 Specification for modules with solder pins

- After screwing the module, all pins must be soldered into the PCB. The hole diameters on the PCB has to be designed according to the soldering pin diameter which is $\text{Ø } 1 \text{ mm} \pm 0.05 \text{ mm}$.
- For further dimensions or a 3D model please contact your local sales manager.

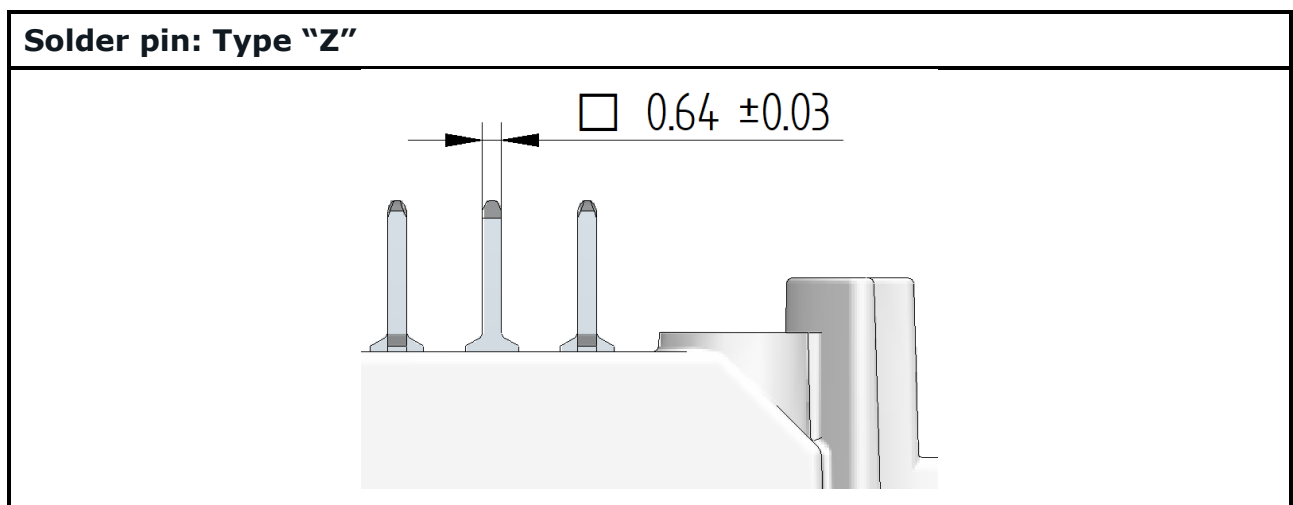

Figure 5: Solder pin diameter

Handling Instructions

for *flow* E3BP packages



Vincotech

2.3 Specification for modules with Press-fit pins that are soldered to the PCB

In cases where the Press-fit pins are soldered instead of pressed into the PCB the recommended PCB hole diameter is stated in the table below. In these cases, the annular ring must be designed according to the standards for through hole components to ensure proper soldering of the Press-fit pins.

	<i>flow</i> E3BP with Press-fit pin type "T"
Final hole diameter	$\varnothing 1.4 \pm 0.1$ mm

Please also read Section 10, *Recommendation for soldering*.

2.4 Required PCB cutouts for plastic housing and screws

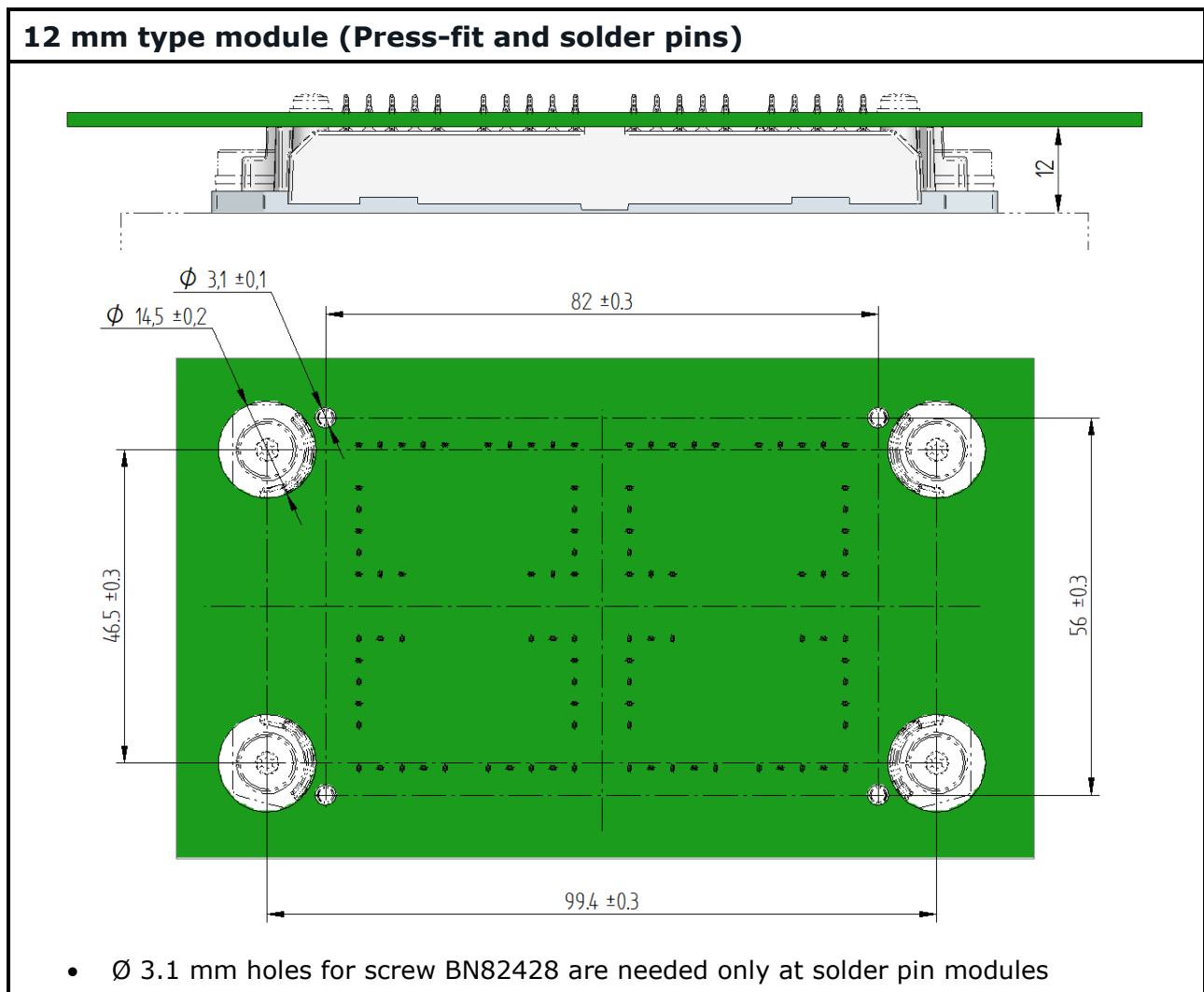

Figure 6: PCB cutouts for 12 mm type module

Handling Instructions

for *flow* E3BP packages



Vincotech

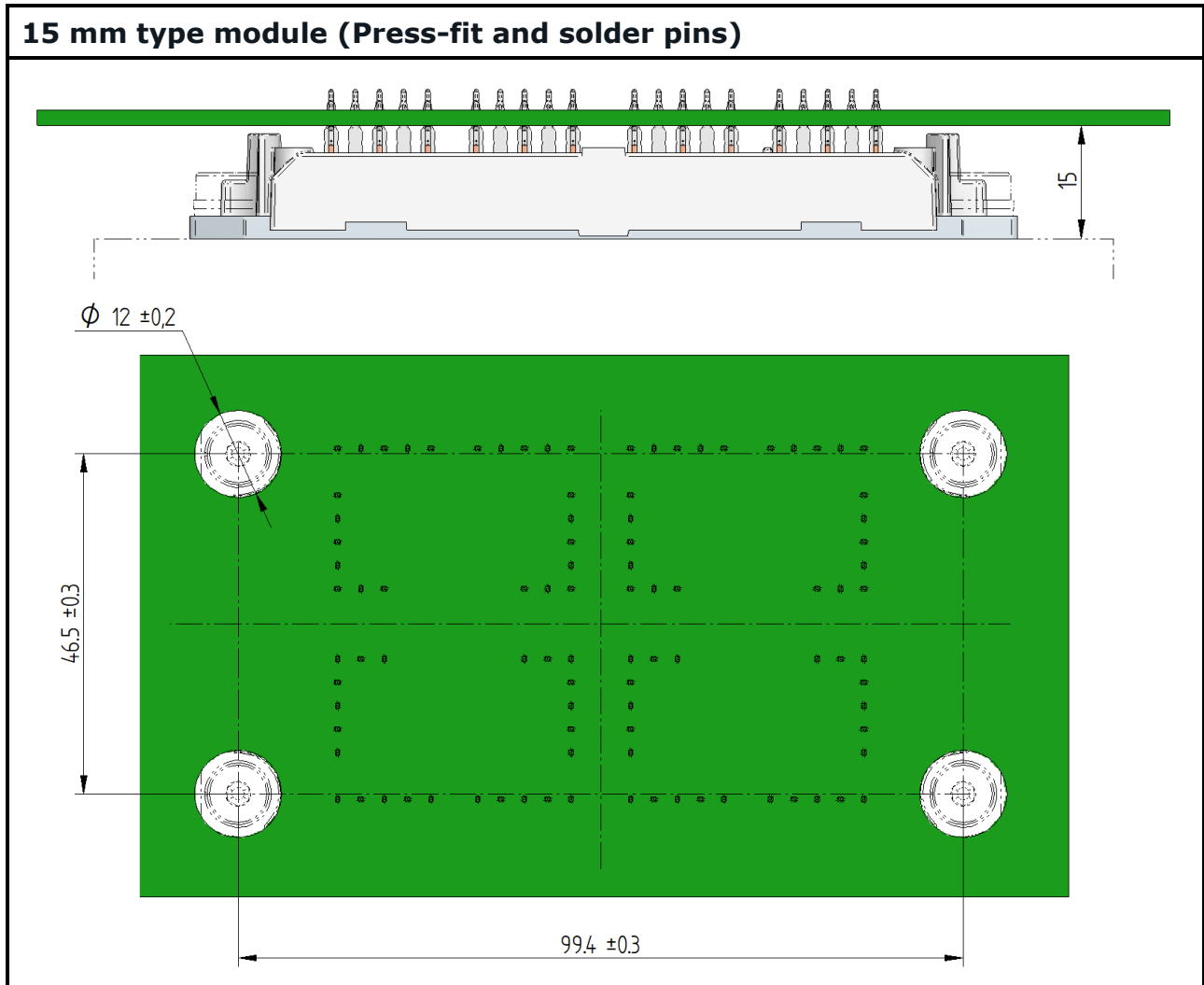

Figure 7: PCB cutouts for 15 mm type module

2.5 Recommended PCB-thicknesses and mounting heights

The distance between the top surface of the heat sink and the bottom plane of the PCB is defined by various parameter:

- housing size:
 - 12 mm
- pin types with various length:
 - Press-fit pin (T-type)
 - Solder pin (Z-type)
- base isolation material (ceramic) type (see product webpage at vincotech.com) and its thickness:
 - aluminum-oxide (Al_2O_3)
 - aluminum-nitride (AlN; relevant only for Press-fit pin modules, see Section 2.5.2)

The different combinations are shown below and grouped by pin types.

Handling Instructions

for *flow* E3BP packages



Vincotech

2.5.1 Solder pin type modules

For fixing the PCB surrounding the module, the housing towers can be used with special screws (see Section 9.1.1)

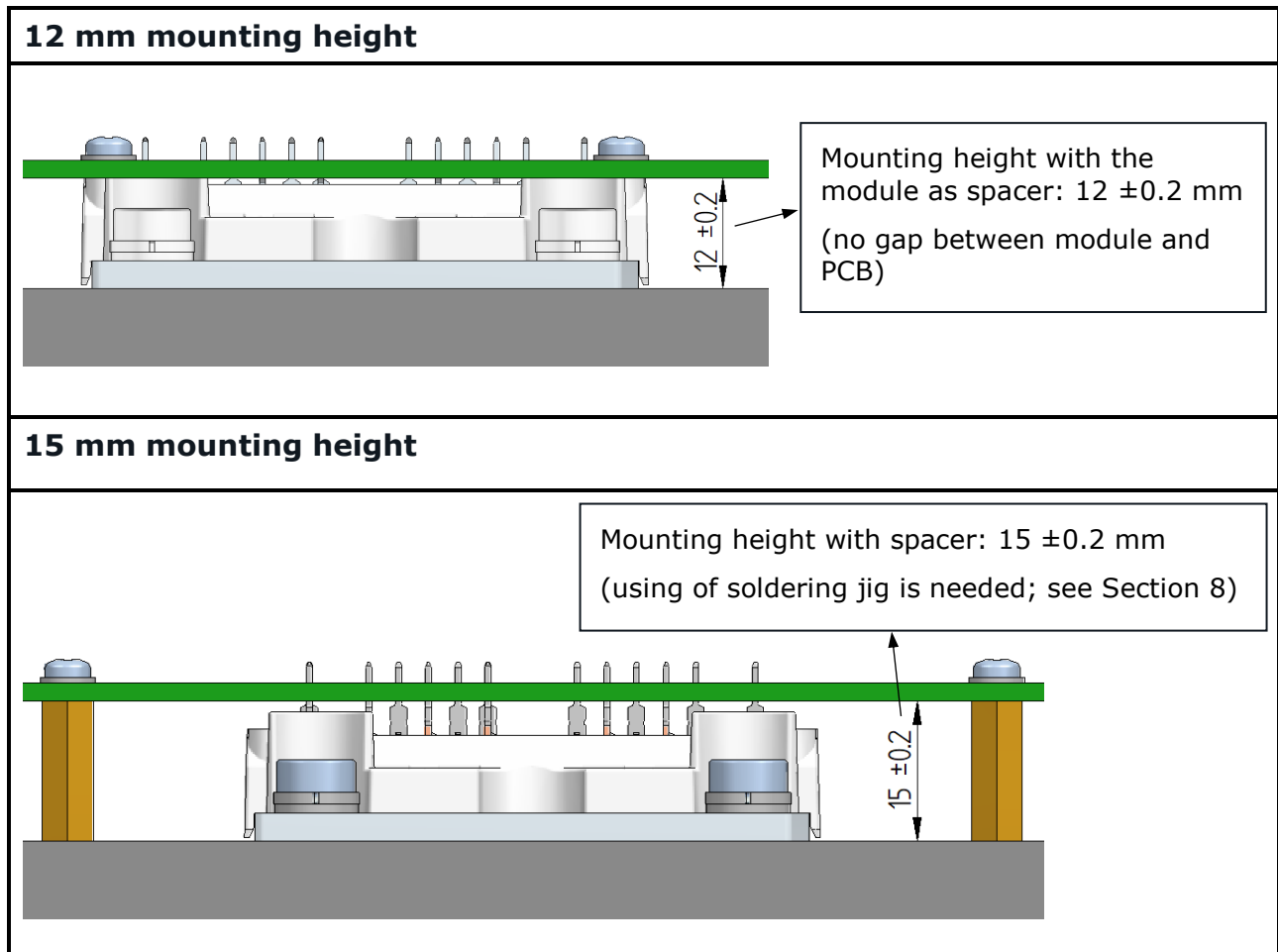

Figure 8: Mounting height for solder pin type module

Handling Instructions

for *flow* E3BP packages



Vincotech

2.5.2 Press-fit pin type modules

For fixing the PCB surrounding the module, spacers can be used (Press-fit pin modules only). The number and the position of the fixing points depend on the design of the circuit, location of different masses like capacitors or inductors and the environment of the system. General recommendation cannot be given. The recommended heights of these spacers are given on the following sections.

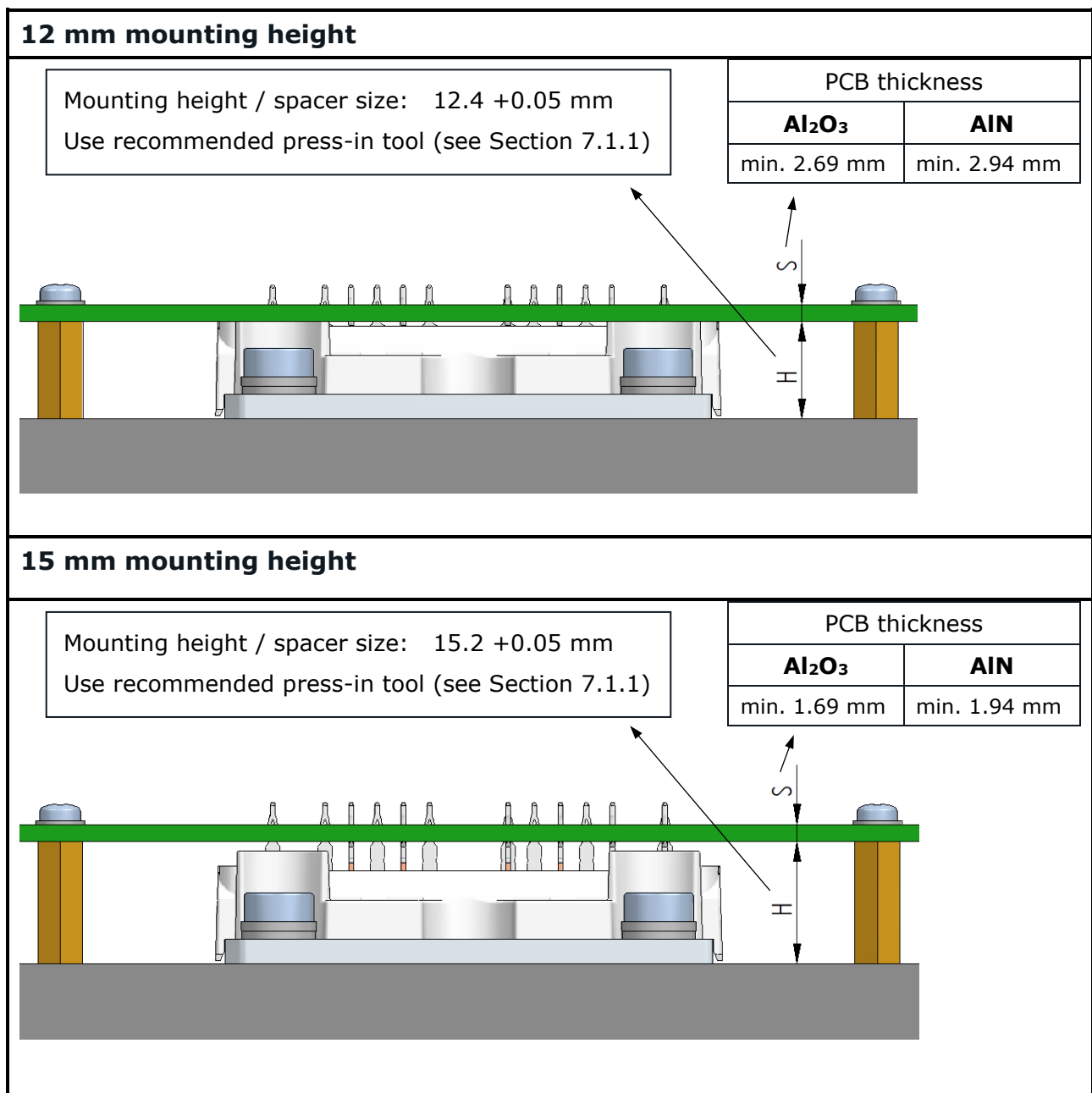

Figure 9: Mounting height and PCB thickness for Press-fit pin type module

Handling Instructions

for *flow* E3BP packages



Vincotech

3 Specification for baseplate

The thermal properties are not affected if the dimensions of the surface imperfections are within the following values.

- Polishing is allowed on the whole nickel plated surface if copper doesn't become visible.
- If copper becomes visible, the unit is scratched and following acceptance criteria should be used. The depth and width of the scratch can't exceed 200 μm and 800 μm , respectively. The length of the scratch does not matter but the total area of scratches must not exceed 5 % of the total substrate surface.

Discolorations and fingerprints are only surface imperfections and do not affect the module's functionality.

Substrate surface imperfections can be seen on the figures below.

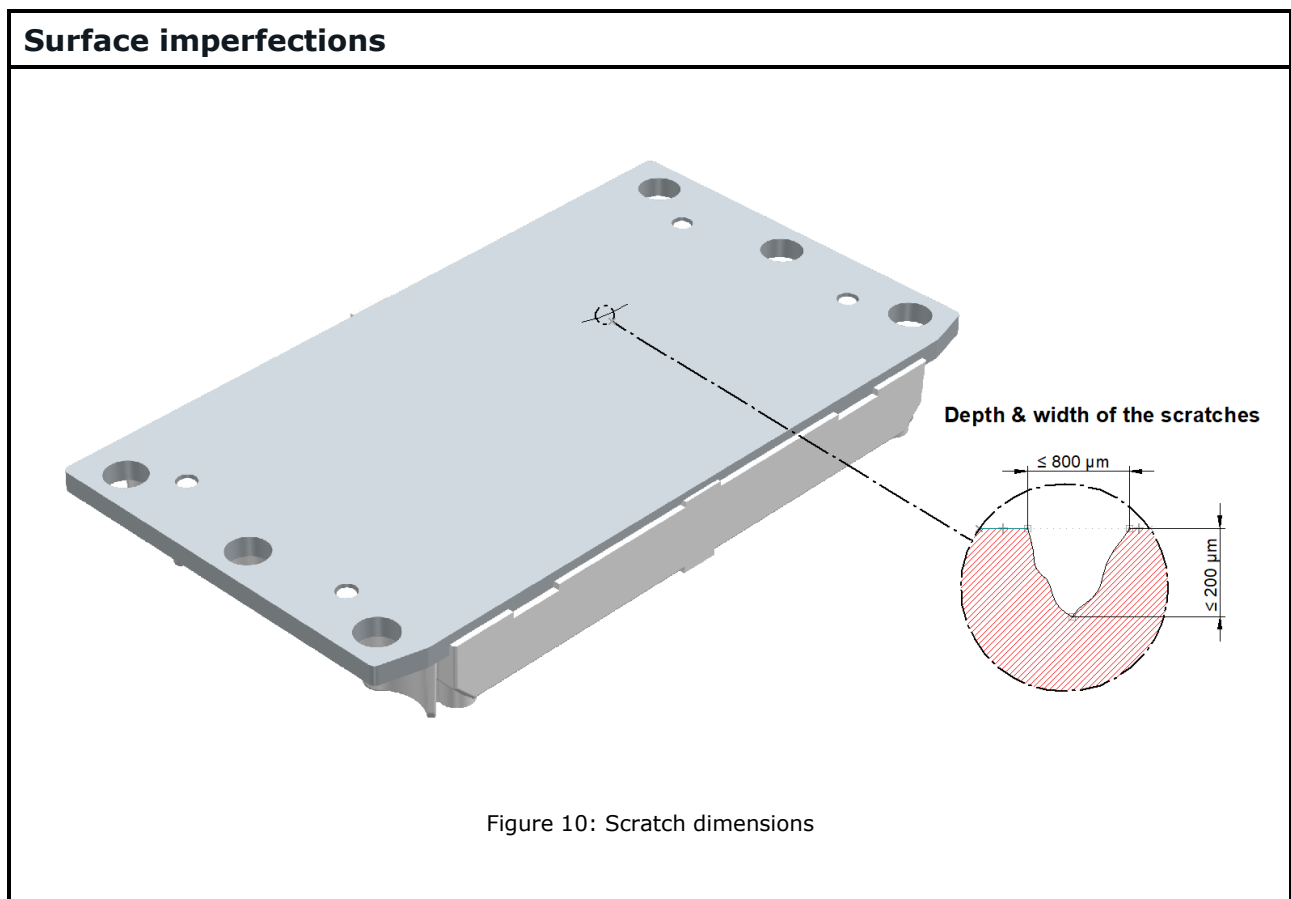

Handling Instructions

for *flow* E3BP packages



Vincotech

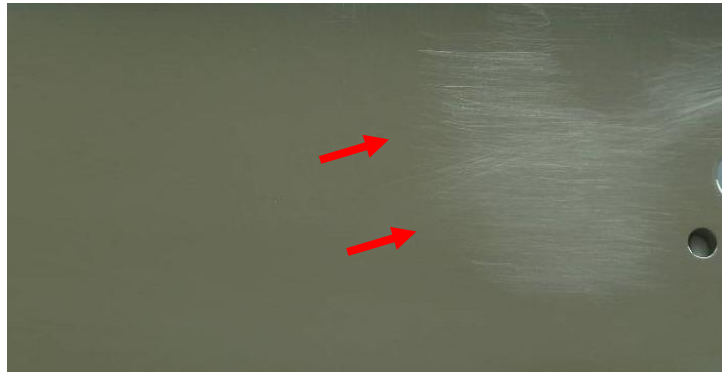

Figure 11: Polished baseplate

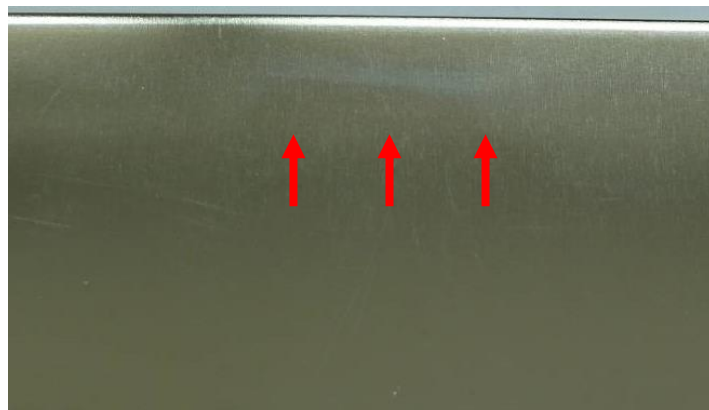

Figure 12: Discoloration of baseplate



Figure 13: Fingerprint on the baseplate

Handling Instructions

for *flow* E3BP packages



Vincotech

4 Specification for heat sinks

The whole heat sink surface under the module must be plane, clean and free of particles.

- The flatness tolerance should be: $< 25 \mu\text{m}$ in general.
- In case the thermal paste is thicker than $50 \mu\text{m}$ the flatness tolerance can be $< 50 \mu\text{m}$.
(A flatness tolerance specifies a tolerance zone defined by two parallel planes within which the surface must lie.)
- The surface roughness should be less than: $R_z < 10 \mu\text{m}$.
- Heat sink surface imperfections should be within the values described for the module baseplate surface (please refer to section 3 Specification for baseplate).

5 Specification for thermal interface materials (TIM)

5.1 Modules with qualified TIM material

- Type of PCM: only **PTM6000HV** from Honeywell
- Applied in a standard honeycomb pattern (see Figure 14 for details)

5.1.1 Modules are available also with pre-applied PCM

- Ordering option code: **- /7/**

Example order: 30-EQ12NIA600H701-PM00F88T -/7
The product will be delivered with PTM6000HV

- In case the module has Press-fit pins, a unique press-in tool has to be used (see section **8.1.1**).
- Further information about using modules with pre-applied TIM see also the application note for "*Power modules with Phase-Change Material*" on Vincotech's website

5.1.2 Modules with non qualified TIM

- usage of thermal grease is not generally qualified and requires application specific evaluation

5.2 Application of TIM

- Pattern: the below pattern and size is recommended (Figure 14)
- Thickness (wet): $90 \pm 20 \mu\text{m}$
- Technology: stencil or screen printing
- For PCM (PTM6000HV):
 - after apply of paste, drying is needed
 - recommended parameters: 45 min at 60°C

Handling Instructions

for *flow* E3BP packages



Vincotech

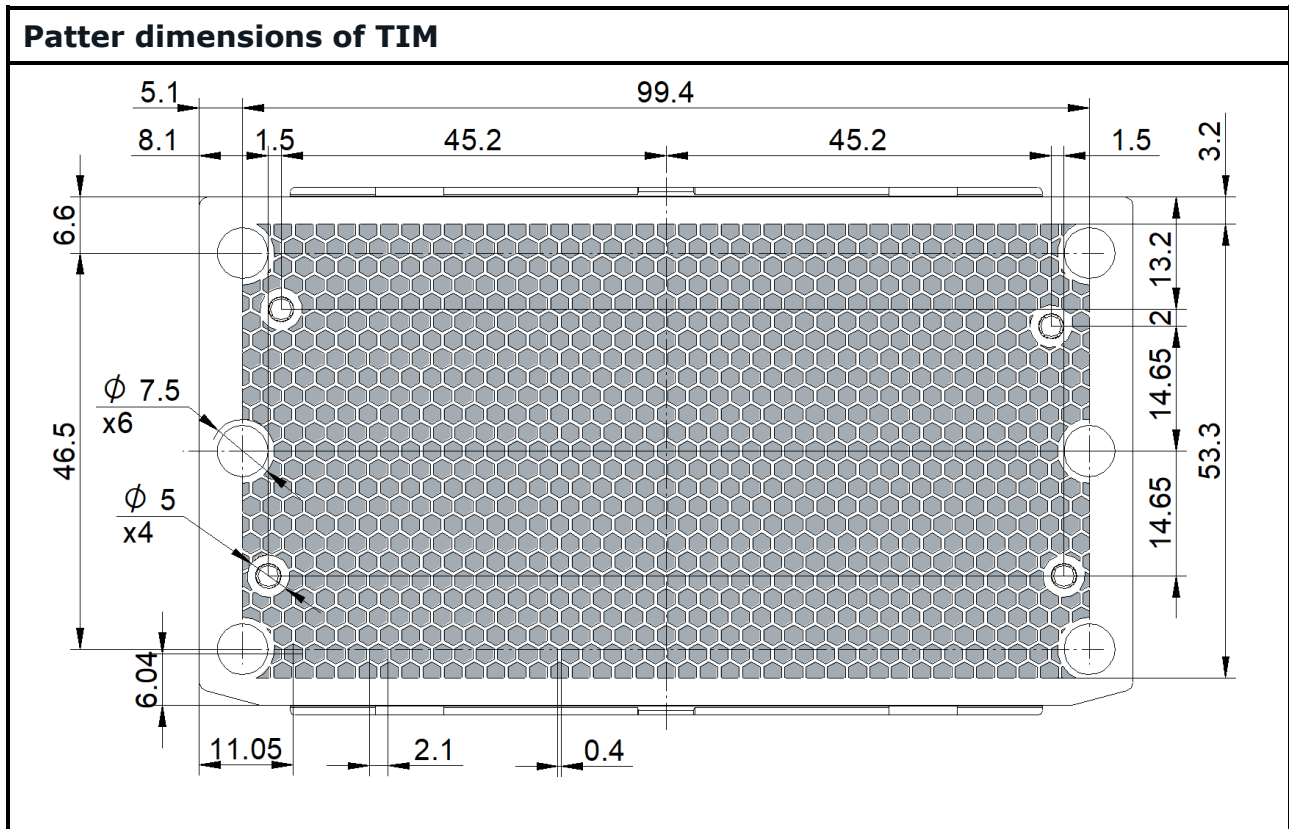

Figure 14: Honeycomb pattern

6 Specification for fastening screws to the heat sink

A torque wrench shall be used to tighten the mounting screws at the specified torque as excessive torque may result in damage or degradation of the device. The inaccuracy of torque wrench tightening method can range up to $\pm 12\%$. This has to be taken into account to prevent over-tightening the fastener.

- Screw size M5, recommended screw type DIN 7984 (ISO14580)
- The recommended material strength class for the screw is 8.8 (ISO-898-1)-any deviation from the recommended material can be used but should be tested
- Flat washer D=max. 10 mm DIN 433 (ISO 7092)
- Spring washer D=max. 10 mm DIN127 or DIN 128
- Mounting torque: $3 \text{ Nm} < M_a < 5 \text{ Nm}$

Due to excessive temperature fluctuations washers should be used to prevent the loosening of the screws. After accurate tightening of the screws the spring washer exerts a constant force on the joint. The flat washer distributes this force on the plastic surface.

Handling Instructions

for *flow* E3BP packages



Vincotech

Tighten screws in the sequence given and shown in below figure:

- 1) Attach the module loosely with two diagonal screws e.g. 1 & 4.
- 2) Tighten screws with 0.5 Nm torque in the following sequence: 1 – 4 – 2 – 3.
- 3) Tighten the screws with final mounting torque in the same sequence.

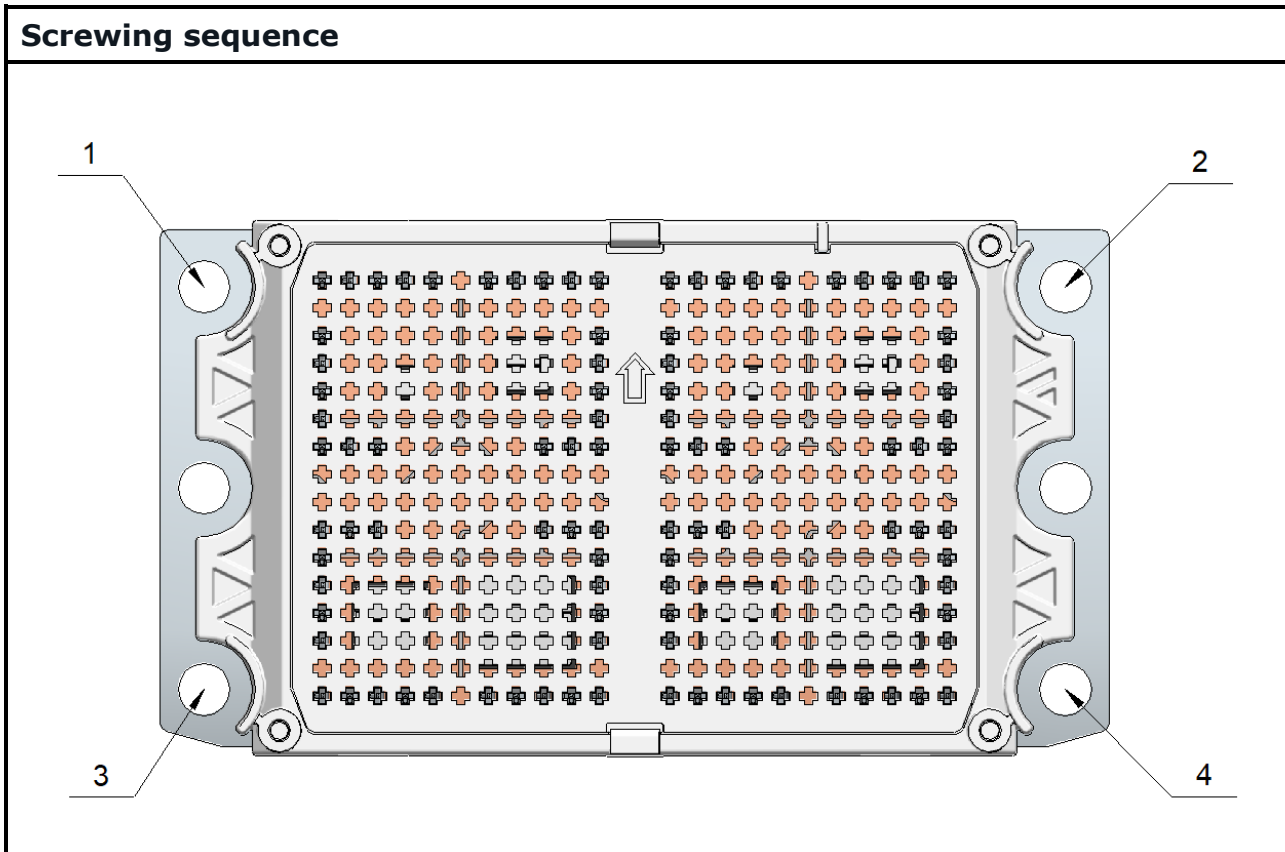

Figure 15: Screw positions in sequence

6.1 Screw with pre-assembled washers

Screws with pre-assembled washers (SEMS or kombi screws) combine the screw and the washers into a single component. These screws eliminate the need to slip the washers into place by hand, boosting the speed and efficiency of the assembly process. The specifications of these screws are provided below:

- Screw size M5 according to DIN 6900 (ISO 10644; JIS B1188)
- The recommended material strength class for the screw is 8.8 (ISO-898-1)-any deviation from the recommended material can be used but should be tested
- Flat washer according to DIN 6902 Type C (ISO 10673 Type S; JIS B1256)
- Size of outer diameter \varnothing 10 mm can be fitted into the module.
- Split lock spring washer according to DIN 6905 (JIS B1251)
- Mounting torque range: $3 \text{ Nm} < M_s < 5 \text{ Nm}$

The worst case of the above specification is considered at Clearance/Creepage distance calculation.

Handling Instructions

for *flow* E3BP packages



Vincotech

6.2 Mounting with automatic screwdriver

For a fast, reliable and repeatable screwing process an automatic screwdriver with two stage tightening method is recommended (screw type same as in Section 6.1). The screwdriver starts fast in the first stage and slows down after the first target torque is reached to accurately tighten the screw to the final target. For torque and speed recommendations see below values, and curves (Figure 16: Recommended torque and speed curve):

Torque

- Cycle start: 0.9 Nm
- First target (pre-tight torque): 1.5 Nm
- Final torque min.: 3 Nm
- Final target: 4 Nm
- Final torque max.: 5 Nm

Speed

- Soft start speed: 96 rpm
- Step 1 speed: max. 650 rpm
- Step 2 speed: max. 12 rpm

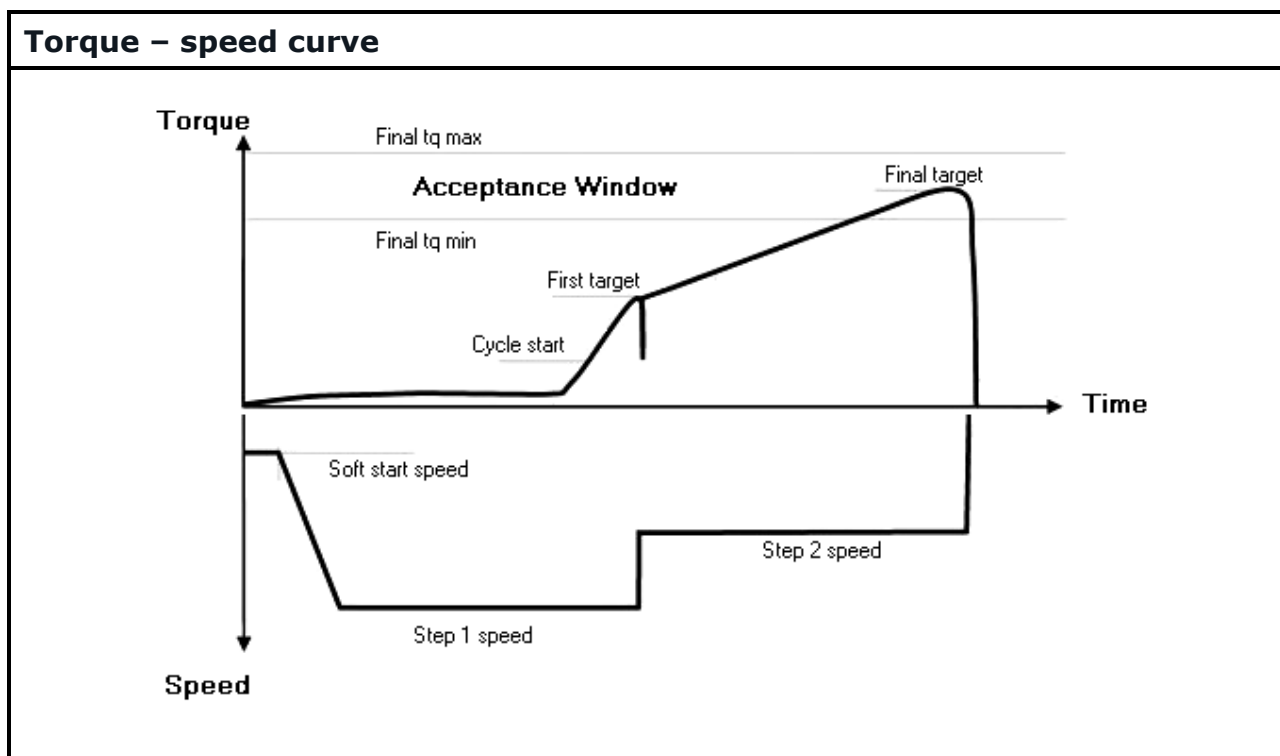

Figure 16: Recommended torque and speed curve

Handling Instructions

for *flow* E3BP packages



Vincotech

7 Press in process of modules with Press-fit pins

7.1 Press-in construction

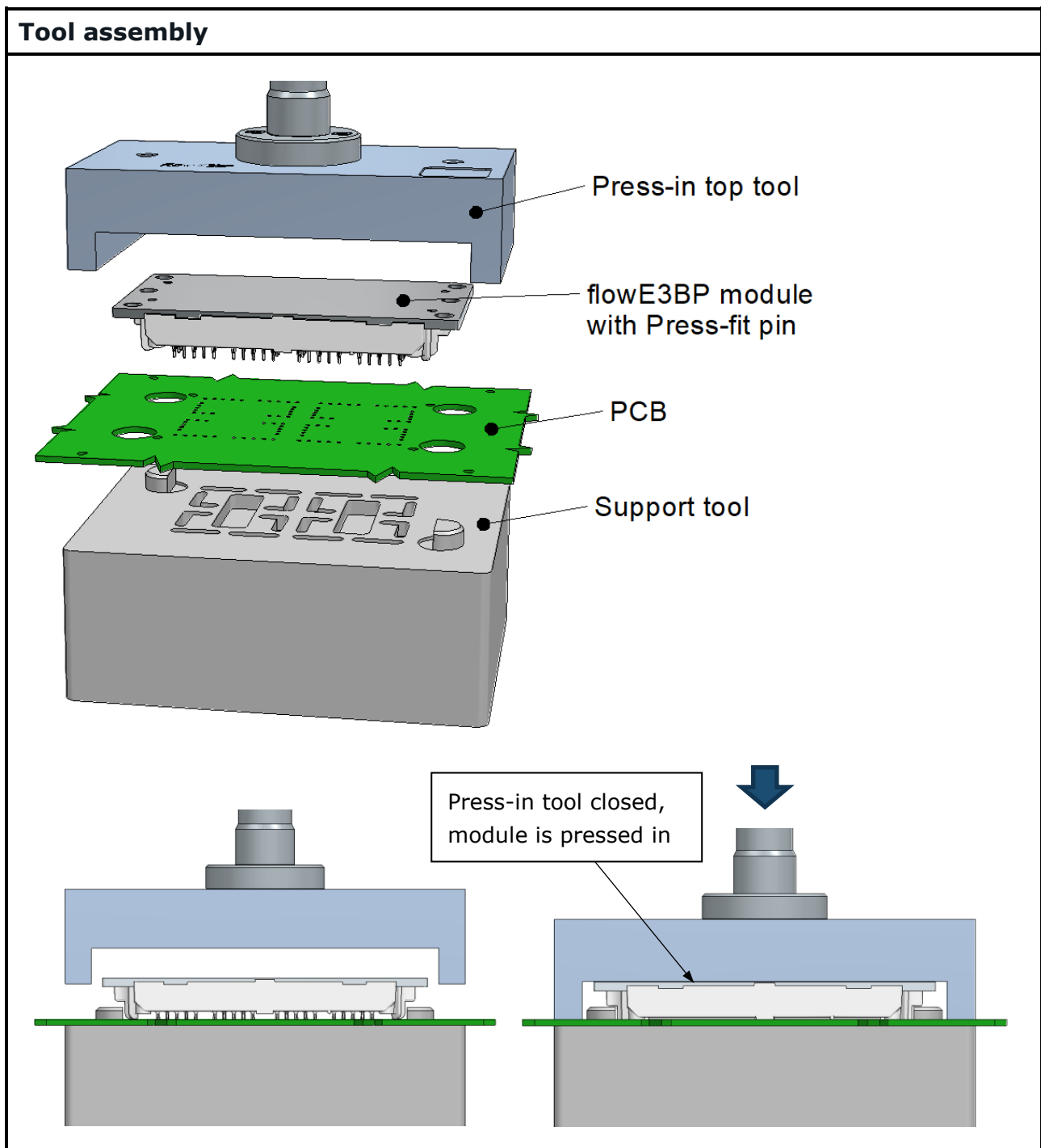

Figure 17: Recommended construction for the press-in process

Handling Instructions

for *flow* E3BP packages



Vincotech

- The module can be pressed into the PCB from the top (as Figure 17) or the PCB can be pressed onto the module from the top (the module is below the PCB).
- The preferred method is to press the module into the PCB from the top. This method will be discussed in this document.
- Pressing multiple modules into one PCB can be done one by one (subsequently) or all at once.
- Pressing multiple modules at the same time requires a press-in tool according to the above detailed single tool. The tool has to ensure the correct leveling of the modules and PCB to avoid mechanical stress.
- The "U-shape" tool is only because to keep the distance between the PCB and the module backside. Depending on the PCB layout the geometry and the position of this distance keeper can be different. Minimum distance between tool and the components on the PCB: 4 mm

7.1.1 Press-in top tool

The press-in tool protects the module from being over pressed. The design is dependent on whether the module is pre-applied with TIM or not.

The dimension marked with 'X' on the drawing (Figure 18 and Figure 19) depends on module height (see below tables).

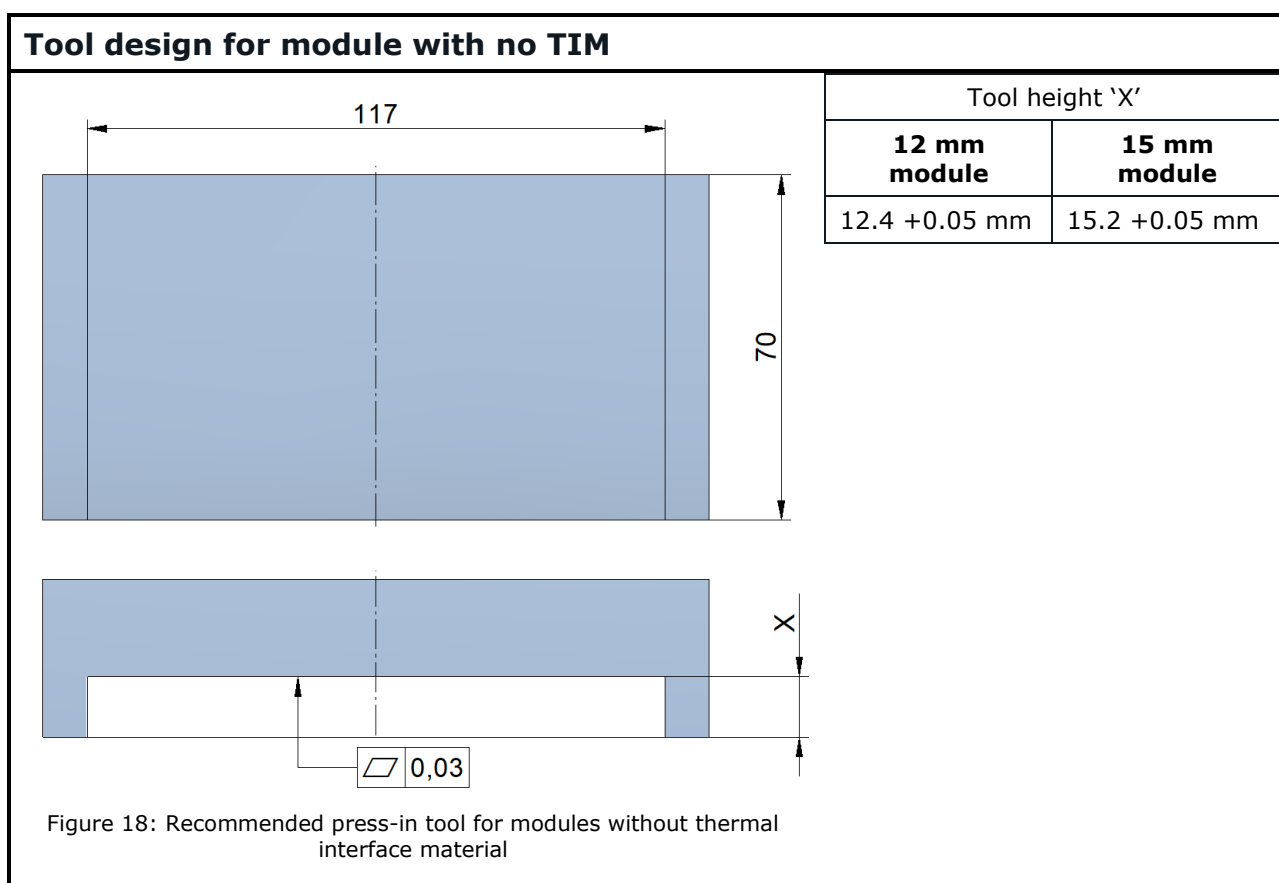

Handling Instructions

for *flow* E3BP packages



Vincotech

A unique press-in top tool shown in Figure 19 is needed to prevent significant damage to the phase change material during the press-in process. Small damages (max: \varnothing 0.6 mm) are allowed.

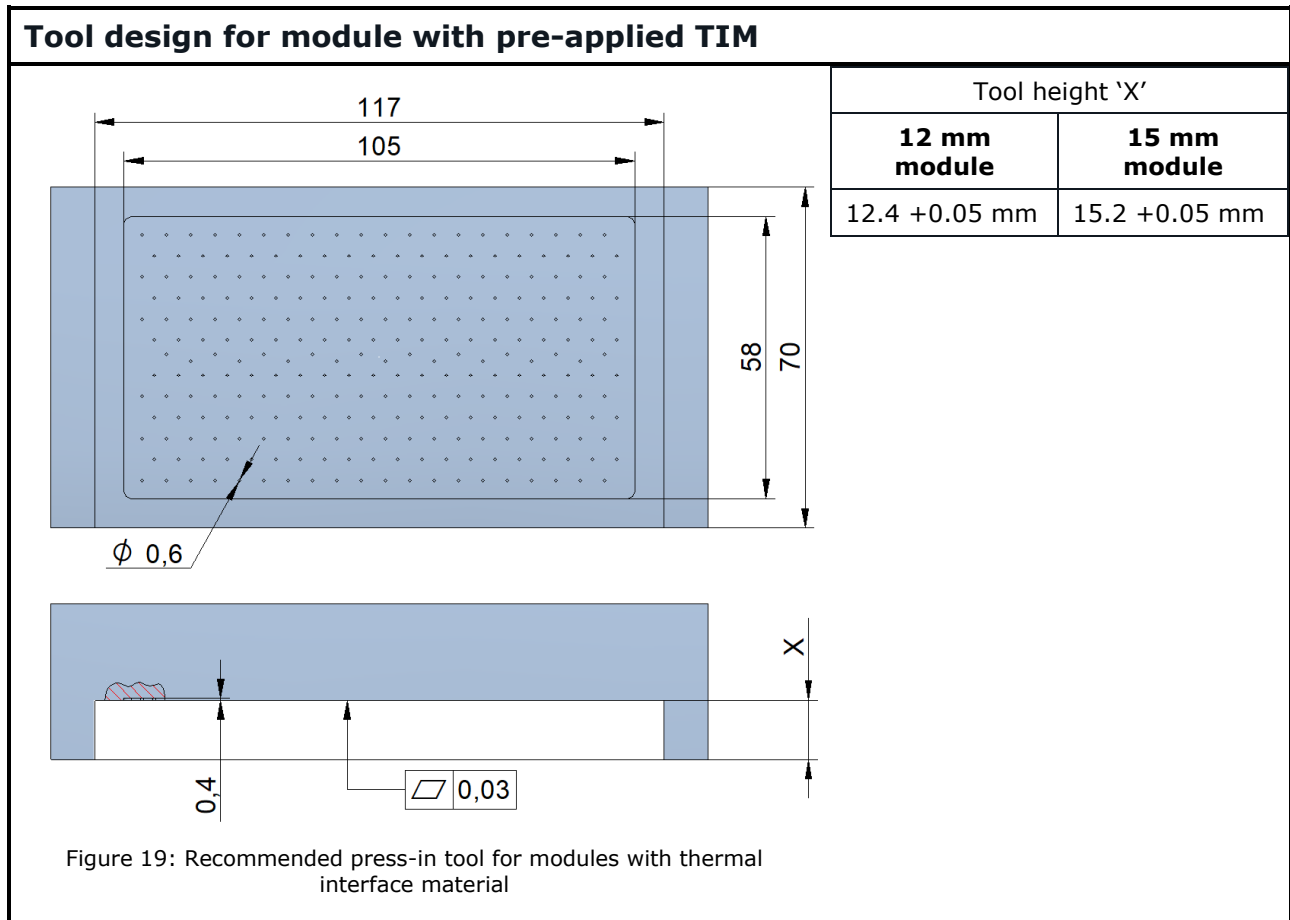

Requirements for the press-in tool:

- Material: tool steel grade 21 MnCr 5 with yield strength of 660 MPa and hardness of 330 HB or better.
- Maintenance: Due to inherent contamination from process and product tolerance differences, it is recommended to clean the press-in tool regularly. The desired cleaning interval is once every 100 modules with soft wipes soaked in Isopropyl alcohol.

For more information or a 3D model please contact your local sales manager.

Handling Instructions

for *flow* E3BP packages



Vincotech

7.1.2 Support tool

- The tool supports the PCB during the press-in process. The size and position of the holes and cutouts depends on the components on the PCB.
- Figure 20 shows the recommended hole and cutout dimensions for the Press-fit pins. The recommended diameter of the holes / cutouts for the pins in the support tool is between 2 ... 4 mm (depending on the positioning accuracy). The minimal supporting place around the pin is 2 mm. If the pins are close to each other then it is possible to make a lengthwise cutout for more pins as well (the min. distance of PCB components from the PCB pinhole should also be considered here). It is necessary to position the PCB and the module as well.
- The module can be positioned with pins from the bottom tool through the fixing holes of the modules.
- Material of the supporting tool: POM (Polyoxymethylene) ESD proof or any metal alloy.
- The thickness of the supporting tool has to be at least 20 mm.

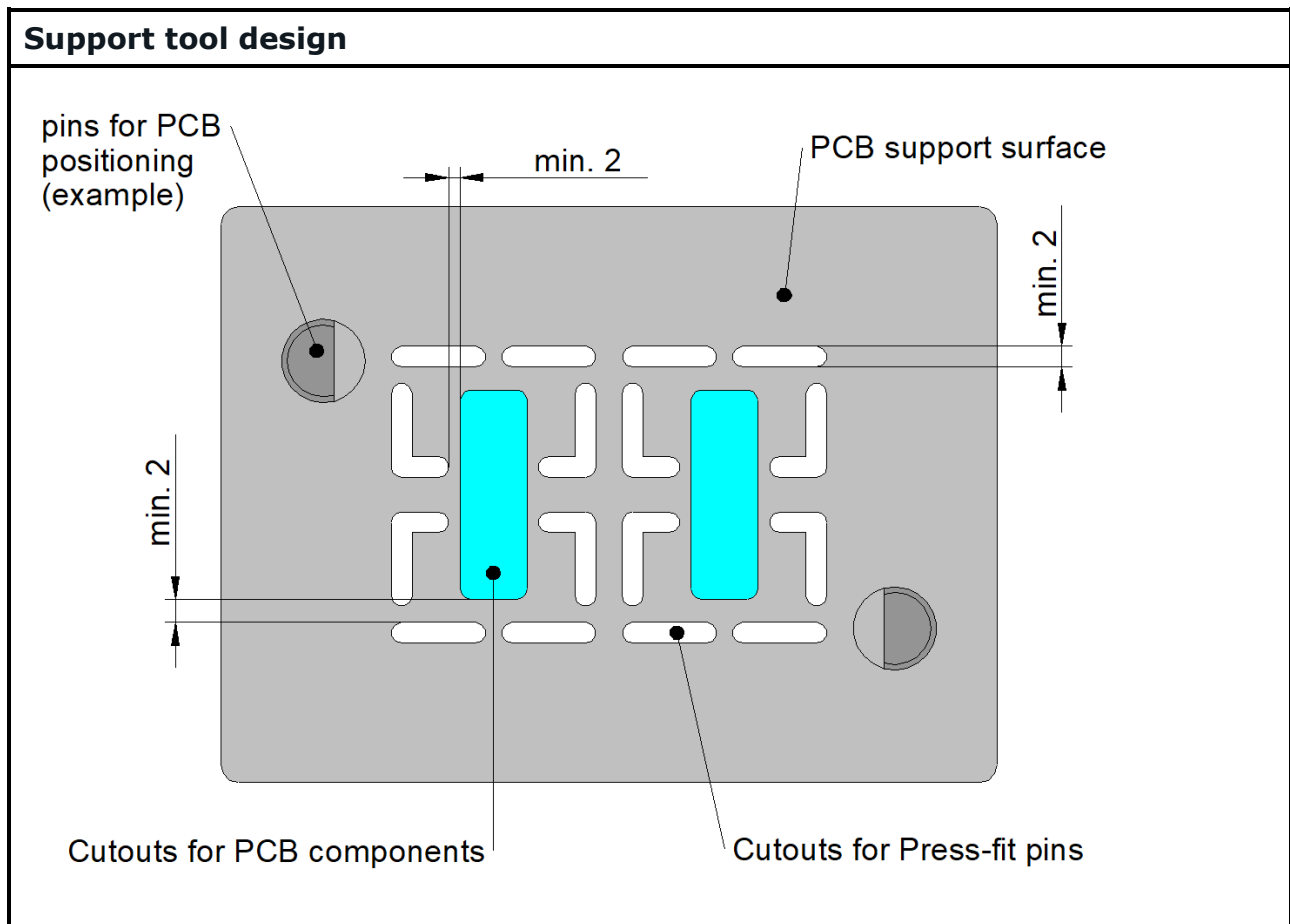

Figure 20: The recommended hole and cutout dimensions for support tool

Handling Instructions

for *flow* E3BP packages



Vincotech

7.2 Press-in process parameters

The total press-in force depends on the number of the pins the hole-diameter and the plating (type/quality) of the PCB.

Press-in process parameters:

- Press-in force: 70 N/pin to 160 N/pin
- Press-in speed: 5 mm/s to 10 mm/s

7.2.1 The basic requirement for the press-in process

The Press-fit pins have to be pressed to the correct depth into the holes of the PCB. The center of the Press-fit zone has to be at least 0.5 mm below the top surface and at least 0.5 mm above the bottom surface of the PCB. (Figure 21).

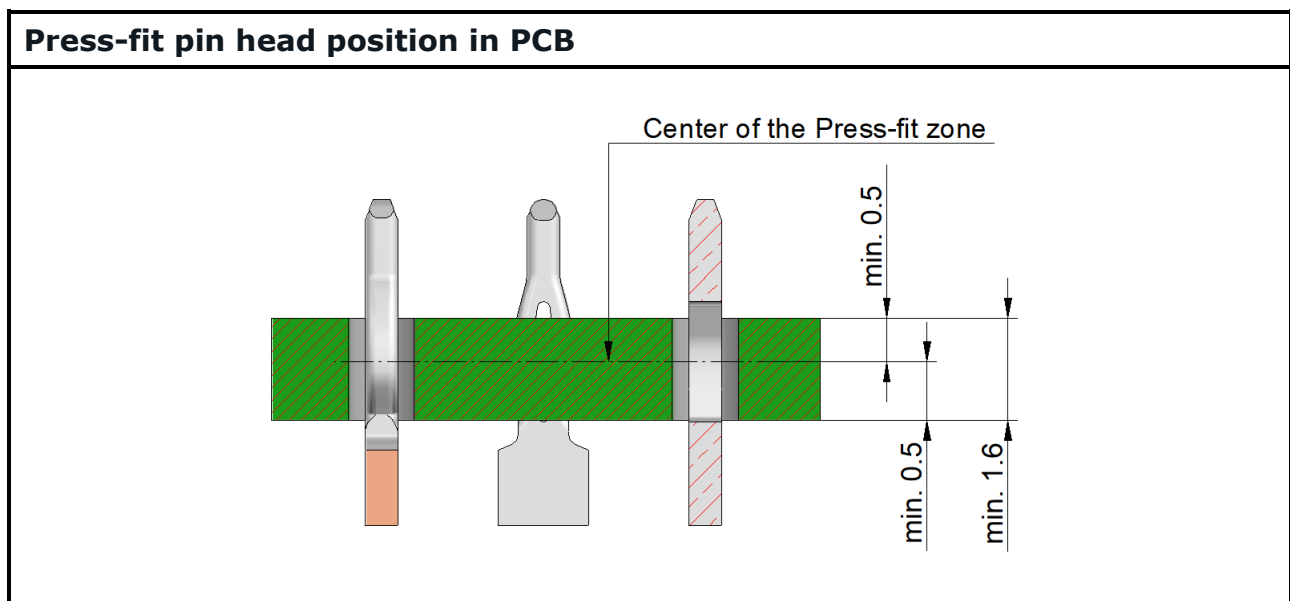

Figure 21: Press-in depth in PCB

This condition is automatically fulfilled with the use of the recommended press-in tool. Figure 17 shows the closed press-in tool with the module.

7.3 Process control parameters

If the press machine is equipped with the possibility to record the force-stroke values during the process, the following quality relevant values should be taken into consideration. Figure 22 shows a normal press-in diagram.

Handling Instructions

for *flow* E3BP packages



Vincotech

Three different sections can be seen on the diagram:

- First raising section (**blue**): The Press-fit zones slide into the holes and deform to fit in the holes. This section ends with a local maximum.
- Second section (**green**): The pin slides in the holes to reach the final position. The center of the Press-fit zones are inside the holes and do not deform any longer. This section ends with a local minimum.
- Second raising section (**red**): press-in tool touches the PCB and the sliding of the pins is stopped. The press-in tool starts to bend the PCB.
- Relaxation section (**black**): after releasing the press-in tool, the PCB, the DCB and the pins can relax, therefore the module height – measured between the DCB backside copper and PCB bottom layer – will be slightly bigger by 0,05...0,2 mm compared to the press-in height ('X' value of press-in tool)

The pressing-in has to be stopped at the beginning of the second raising section, not exceeding the actual max force of the first rising section, to avoid damaging the PCB or the deformation of the plastic housing. The press-in force or the motion stroke of the tool has to be controlled to stop at the beginning of the second raising section.

Possible process control parameter settings are as follows:

- The local maximum value (end of blue section) of the force-stroke diagram has to be:
 - higher than 70 N x number of the pins,
 - smaller than 160 N x number of the pins.
- These limits are marked on the diagram. If the press-in force does not fit in the interval defined above, it can indicate faulty plating, or improper diameter of the holes.

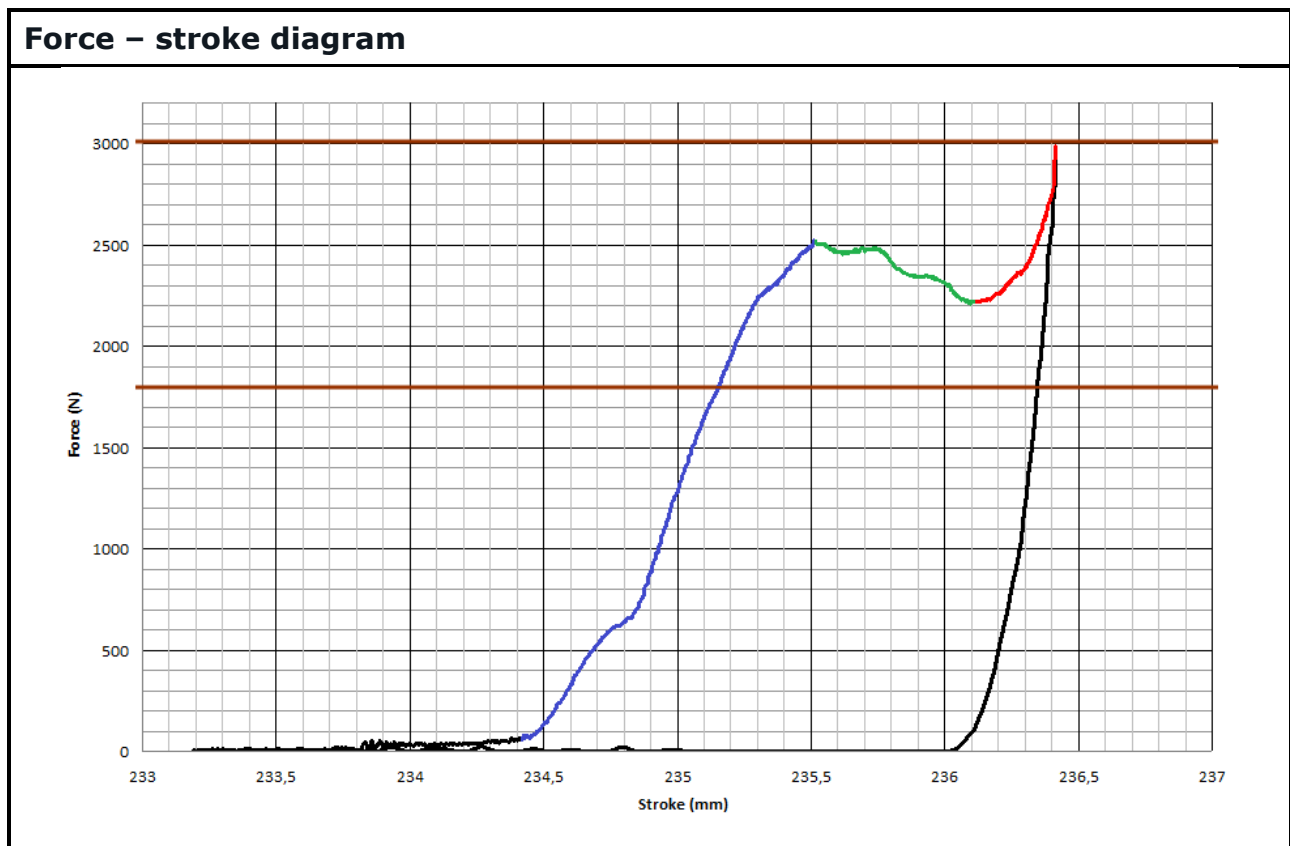

Figure 22: Typical press-in diagram of a 20 pin module



8 Press-out process for modules with Press-fit pins

Please note: In the case an out-pressed module should be used again, it is necessary to solder the module to the PCB because of the remaining deformation of the pins. This is because the Press-fit zone will keep a remaining deformation after the press-out process. An additional press-in cycle will result in low holding forces between the Press-fit pin and the PCB hole. Additional information for the annular ring can be found in section 2.3.

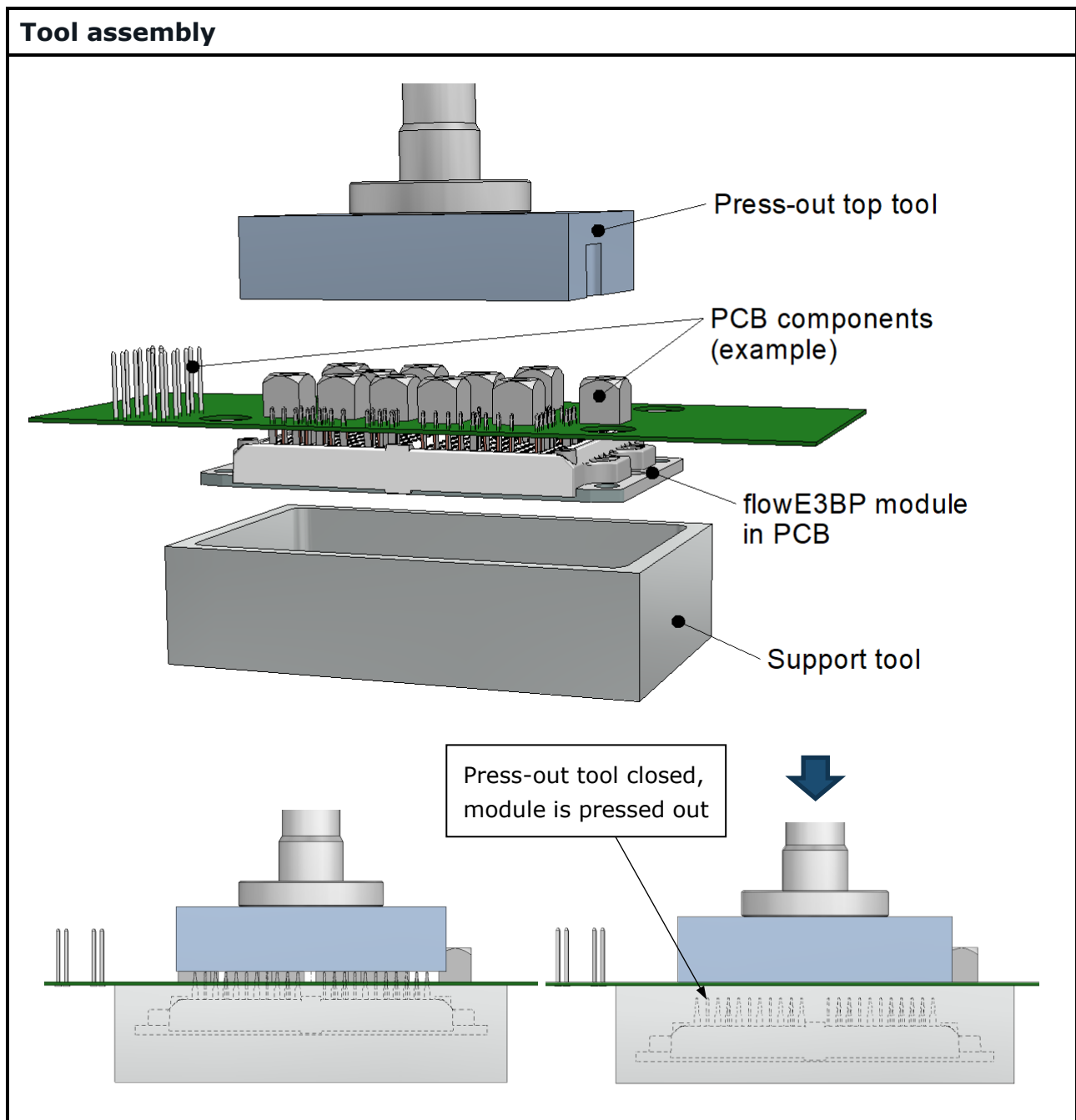

Figure 23: Recommended construction for the press-out process

Handling Instructions

for *flow* E3BP packages



Vincotech

8.1 Press-out tool

The specific tool to disassemble the modules from the PCBs has two parts similar to the press-in tool:

- The support tool serves as a backing for the PCB. The recommended size of the backing nest is slightly bigger than the overall dimensions of the module for supporting the PCB as close as possible to the module. There may be components mounted to the PCB in the area of the backing. It is possible to cut out the nest in this case.
- The press-out top tool is a flat plate, including with cutouts for possible PCB components. It is not possible to press-out the module with a flat plate if the PCB is thicker than 2.5 mm due to not enough overhang of the pins. In this case, pressing sticks accurately positioned according to the pin layout are necessary.

8.2 Press-out process characteristics

After inserting the module into the nest, the pins are pressed through by the onward moving press-out top tool.

Press-out process parameters:

- Press-out force: Higher than 40 N/pin
- Press-out speed: 2 mm/s to 5 mm/s

Figure 24 shows a typical force-stroke diagram of the press-out process for a 20 pin module. It is typical for this curve that a characteristic peak appears which indicates the breaking of the cold welded connection.

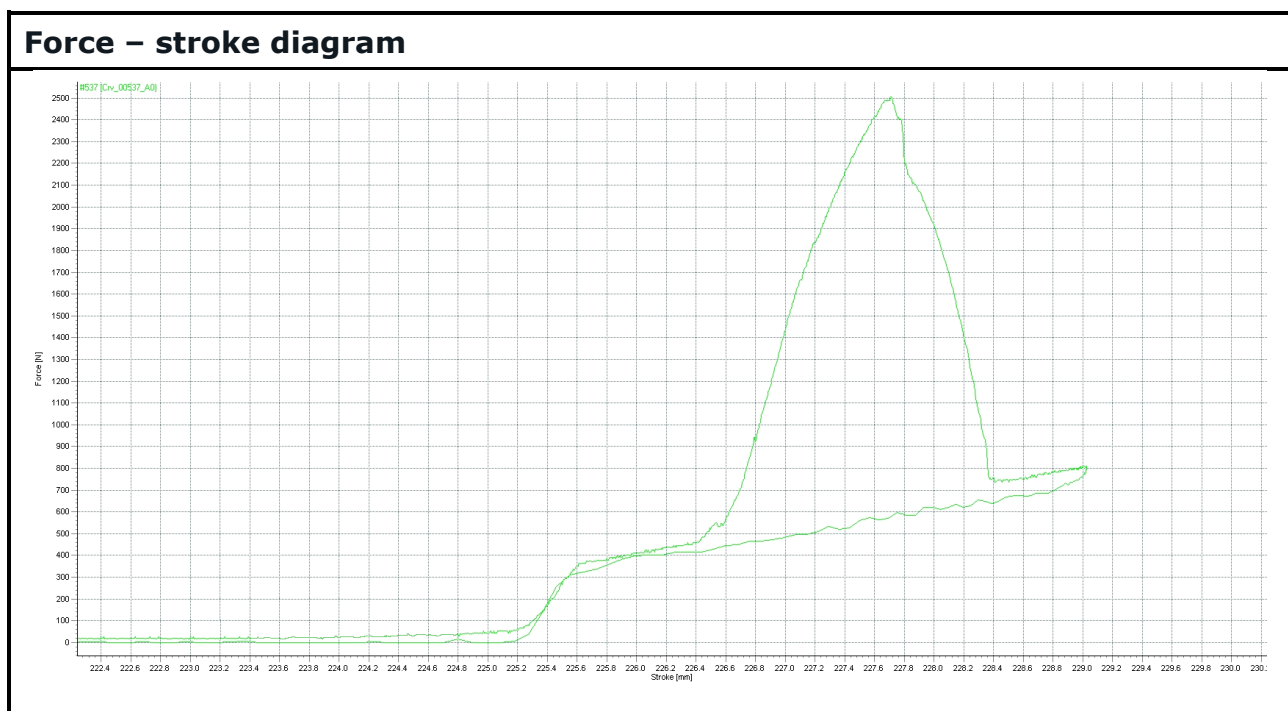

Figure 24: Force-path diagram of the press-out process

Handling Instructions

for *flow* E3BP packages



Vincotech

8.3 Disassembling by hand

If the Press-fit zone is overlapped by the PCB in such a way that the spring-end is out of the PCB, the disassembling is possible hand pliers. The cutting should be done in such a way that the cutting edge is under the area where the two parts of the Press-fit zone join shown as a blue line in Figure 2525. After clipping away all of the Press-fit zones, it is possible to remove the module from the PCB.

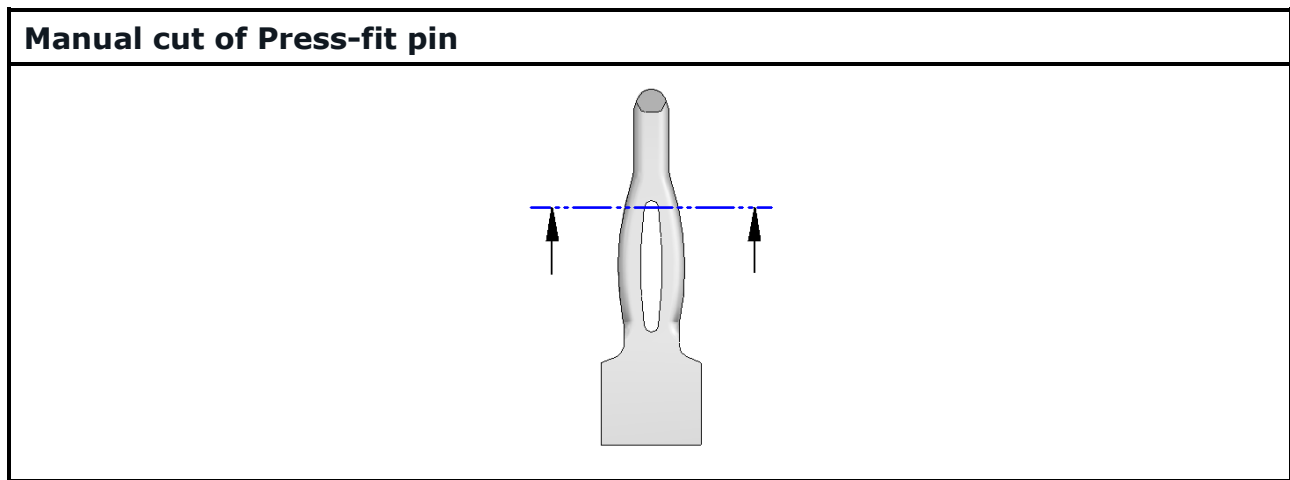

Figure 25: Cutting edge

9 Mounting of modules with solder pins

9.1 12 mm modules

- for minimum overhang of pins IPC-A-610E standard and module datasheet drawing should be considered

9.1.1 Using screws to fix the module to the PCB

- Insert the module pins into the PCB
- Fix the module to the PCB with 4 screws by the towers before soldering. (for screws min. $\varnothing 2.8$ mm hole is needed on PCB)
- Screw type BN82428, $D = 2.5$ mm and $L = 6$ mm with a mounting torque of 0.4 Nm.
- Recommendation for spacer:
 - not necessary to use surrounding the module
 - general heights can be seen in section 2.5

Handling Instructions

for *flow* E3BP packages



Vincotech

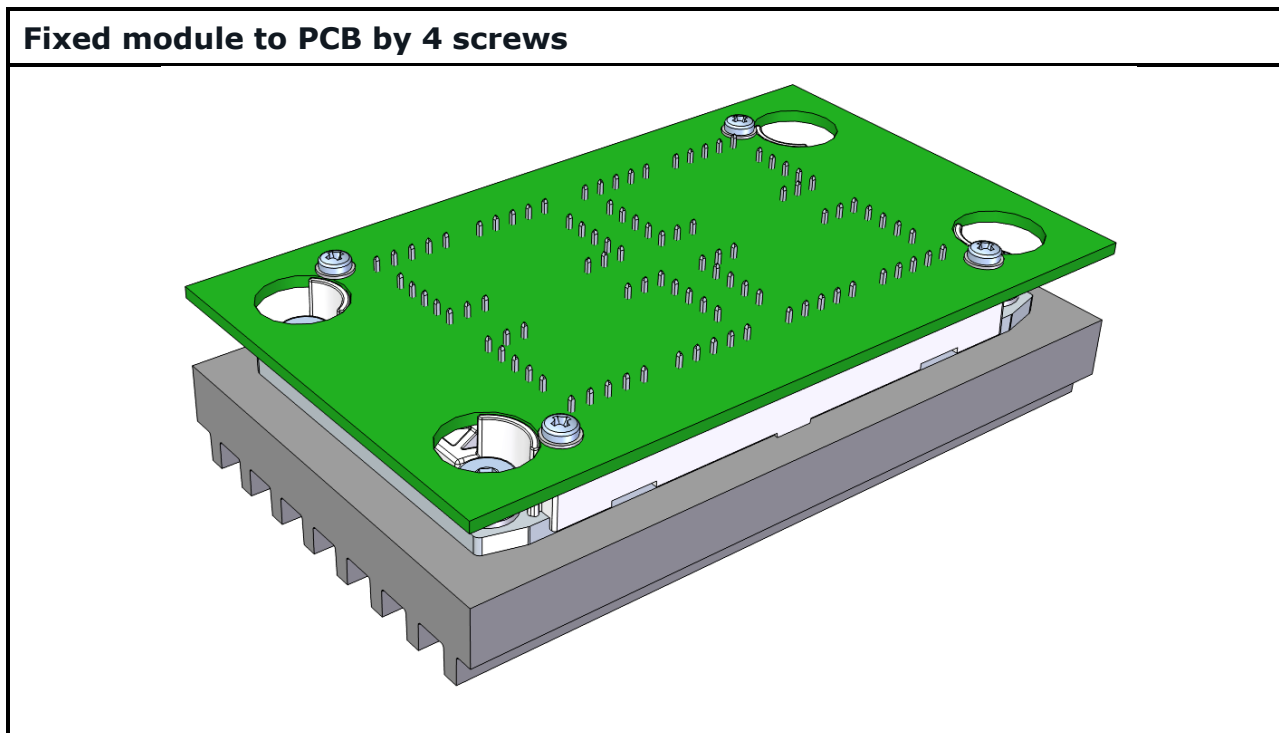

Figure 26: Assembly illustration

9.1.2 Using soldering jig (without using screws)

- insert the module pins into the PCB
- fix the module to the PCB with soldering jig before soldering process
- use spacers also surrounding the module
- solder jig height should be set to the applied spacer height

9.2 15 mm modules

- 15 mm solder pin type module can be assembled only with the help of soldering jig
- for minimum overhang of pins IPC-A-610E standard and module datasheet drawing should be also considered here

9.2.1 Using soldering jig

- insert the module pins into the PCB
- fix the module to the PCB with soldering jig before soldering process
- use spacers also surrounding the module
- solder jig height should be set to the applied spacer height

10 Recommendation for soldering

10.1 Solderability specification

- Plated through holes should exhibit a vertical solder fill of 75 %, with a fully formed fillet on the solder side and evidence of 75 % wetting on the component side lead, barrel and pad.

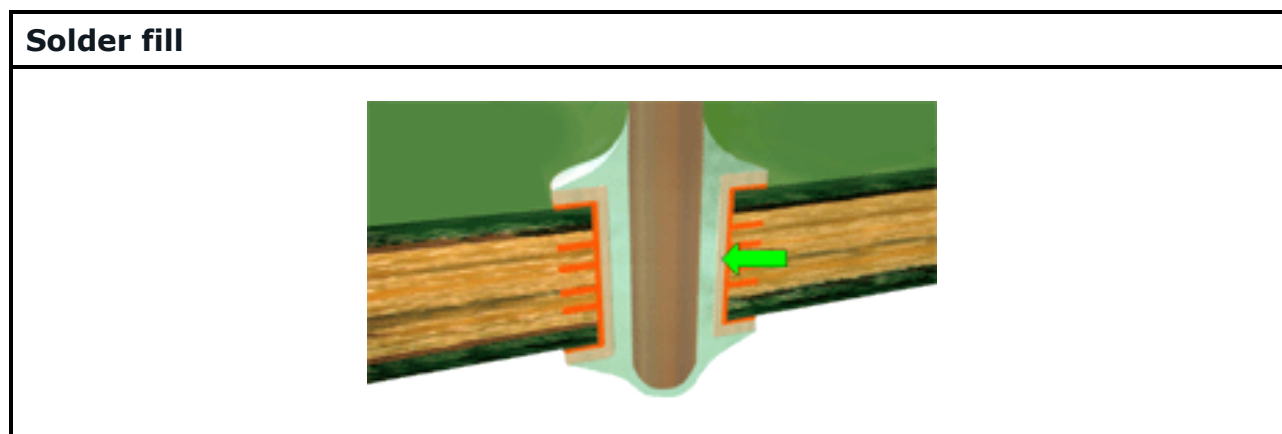

Figure 27: Plated through hole, good soldering

- The solder pins of the *flow* E3BP modules are plated with a nickel underlayer and a continuous tin finish to promote solderability. The tin finish can be discoloured due to production process or storage conditions. This is merely a cosmetic imperfection and does not influence the solderability of pins. Different solder pins on the same module may exhibit different levels of discoloration as shown in the examples in Figure 28.

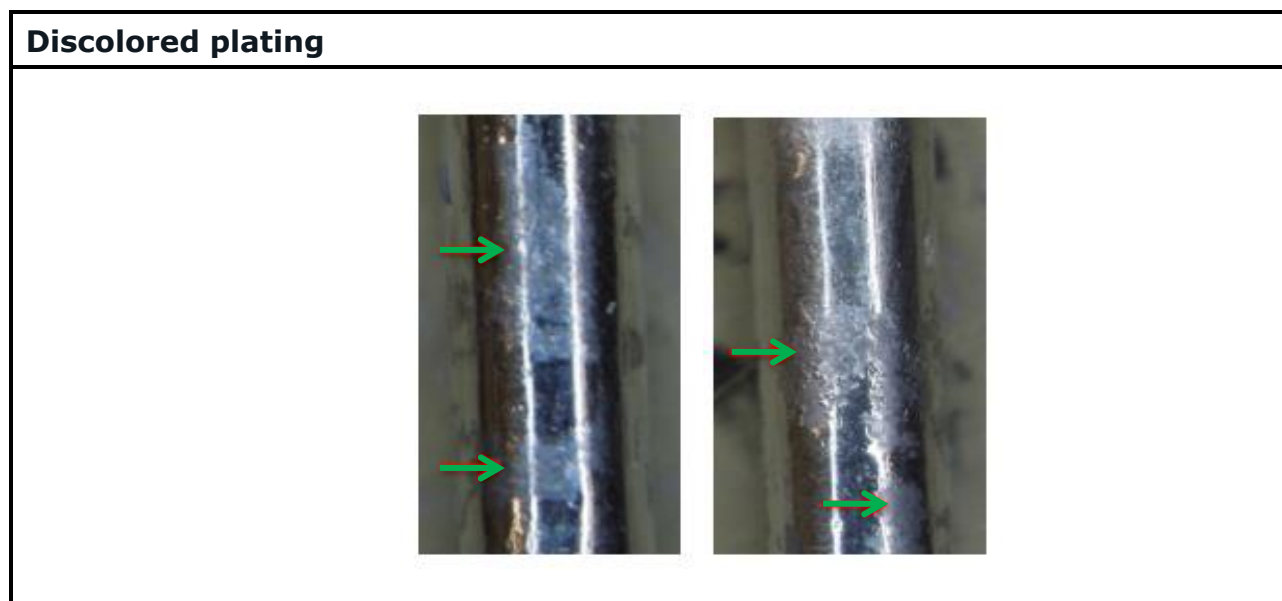

Figure 28: Examples of discolored solder pins

Handling Instructions

for *flow* E3BP packages



Vincotech

10.2 Wave soldering of modules with solder pins

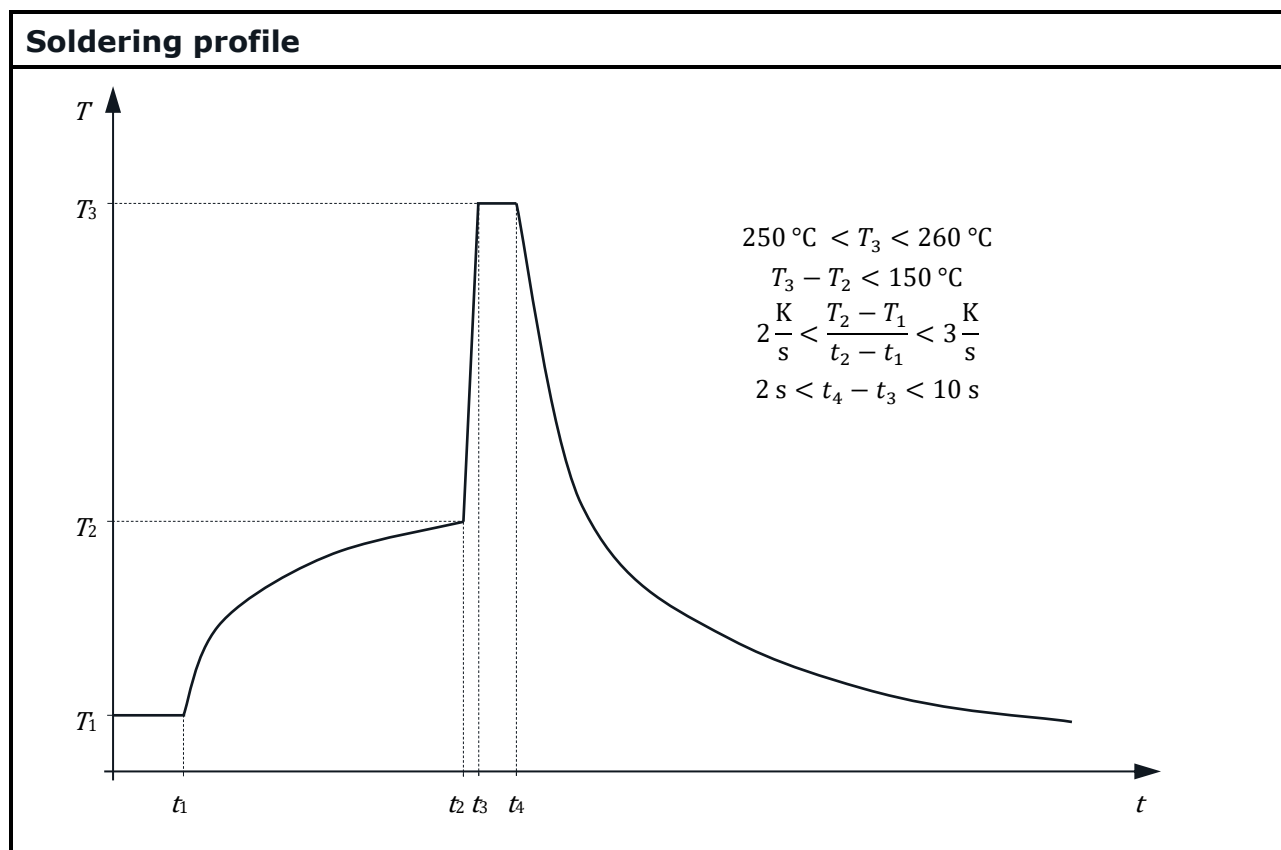

Figure 29: Typical profile for wave soldering

Soldering of certain modules with Press-fit pins is also possible using the wave soldering process. Wave soldering cannot be performed on all type of Press-fit modules.

10.3 Hand soldering parameters

- Max. solder iron temperature: 350 °C
- Max. contact time with component lead: 10 s
- Number of heat cycles: 3

Handling Instructions

for *flow* E3BP packages



Vincotech

11 ESD protection

Modules are sensitive to electrostatic discharge which can damage or destroy sensitive semiconductors. All modules are ESD protected in the shipment box by semi conductive plastic trays. During the handling and assembly of the modules it is recommended to wear a conductive grounded wrist band and ensure a conductive grounded working place.

The modules have the following ESD sensitivity levels according the ESD Association classification:

ESD STM5.1-1998 Human Body Model:	Class 0
ESD STM5.2-1999 Machine Model:	Class M1
ESD STM5.3.1-1999 Charged Device Model:	Class C1

Please take into consideration the following standards for handling electrostatic-sensitive devices: EN61340-5-1, ANSI S20.20

12 Environmental conditions

The modules can be subjected to environmental conditions characterized by the following classes:

Storage:	1K2 / 1B1 / 1C1 / 1S2 / 1M2
Transportation:	2K2 / 2B1 / 2C1 / 2S1 / 2M2*
Operation:	3K3

These classes are defined in the IEC 60721-3-1, IEC 60721-3-2 and IEC 60721-3-3 standards. Modules stored with the above storage conditions must be mounted within the following time period after the module manufacturing date (module date code):

Shelf-life	<i>Without TIM</i>	<i>With pre-applied TIM</i>
<i>With solder pins</i>	1 year	1 year
<i>With Press-fit pins</i>	2 years (1 year if soldered)	1 year

Flammability classification of the plastic material for *flow* E3BP packages are V-0 and 5-VA (self-extinguishing, no dripping of flaming particles) according to UL 94, IEC 60695-11-10 and IEC 60695-11-20 test methods.

12.1 Parameters of environment classes

The parameters detailed below are for informative purposes only. This section does not substitute the above mentioned standards. Please read the IEC 60721-3-1 and IEC 60721-3-2 standards for the description of the environment classes.

12.1.1 Climatic conditions

1K2

Air temperature: 5 °C to 40 °C

Humidity: 5 % to 85 % RH but max. 1 g/m³ to 25 g/m³ absolute

Handling Instructions

for *flow* E3BP packages



Vincotech

Rate of change of temperature:	0.5 °C/min
Air pressure:	70 kPa to 106 kPa
Solar radiation:	700 W/m ²
Movement of surrounding air:	1 m/s
Condensation:	No
Precipitation:	No
Water from other sources than rain:	No
Formation of ice and frost:	No

2K2

Temperature:	-25 °C to 60 °C
Change of temperature air/air:	±25 °C
Relative humidity not combined with rapid temperature changes:	max. 75 % (at 30 °C temperature)
Relative humidity combined with rapid temperature changes:	No
Low air pressure:	70 kPa
Change of air pressure:	No
Solar radiation:	700 W/m ²
Movement of surrounding air:	No
Precipitation:	No
Heat radiation:	No
Water from other sources than rain:	No
Wetness:	No

3K3

Relative humidity:	5% to 85%
Absolute humidity:	1 g/m ³ to 25 g/m ³
Condensation:	No
Precipitation:	No
Formation of ice:	No

12.1.2 Biological conditions

1B1

Flora and fauna:	Negligible
------------------	------------

2B1

Flora and fauna:	No
------------------	----

12.1.3 Chemically active substances

1C1

Handling Instructions

for *flow* E3BP packages



Vincotech

Sea and road salts:	No (Salt mist may be present in sheltered locations of coastal areas.)
Sulphur dioxide:	0.1 mg/m ³
Hydrogen sulphide:	0.01 mg/m ³
Chlorine:	0.01 mg/m ³
Hydrogen chloride:	0.01 mg/m ³
Hydrogen fluoride:	0.003 mg/m ³
Ammonia:	0.3 mg/m ³
Ozone:	0.01 mg/m ³
Nitrogen oxides:	0.1 mg/m ³ (Expressed in equivalent values of Nitrogen dioxide.)

2C1

Sea salts:	none
Sulphur dioxide:	0.1 mg/m ³
Hydrogen sulphide:	0.01 mg/m ³
Nitrogen oxides:	0.1 mg/m ³ (Expressed in the equivalent values of Nitrogen dioxide.)
Ozone:	0.01 mg/m ³
Hydrogen chloride:	0.1 mg/m ³
Hydrogen fluoride:	0.003 mg/m ³
Ammonia:	0.3 mg/m ³

12.1.4 Mechanically active substances

1S2

Sand:	30 mg/m ³
Dust (suspension):	0.2 mg/m ³
Dust (sedimentation):	1.5 mg/(m ² h)

2S1

Sand in air:	No
Dust (sedimentation):	No

12.1.5 Mechanical Conditions

1M2

Stationary vibration, sinusoidal

Frequency range:	2 Hz to 9 Hz
displacement amplitude:	1.5 mm
Frequency range:	9 Hz to 200 Hz
peak acceleration:	5 m/s ²

Non stationary vibration, including shock

Shock response spectrum type L	
peak acceleration:	40 m/s ²

Static load: 5 kPa

Handling Instructions

for *flow* E3BP packages



Vincotech

2M2

Stationary vibration sinusoidal

- Frequency range: 2 Hz to 9 Hz
- displacement amplitude: 3.5 mm
- Frequency range: 9 Hz to 200 Hz
- peak acceleration: 10 m/s²
- Frequency range: 200 Hz to 500 Hz
- peak acceleration: 15 m/s²

Stationary vibration, random

- Acceleration spectral density: 1 m²/s³
- Frequency range: 10 Hz to 200 Hz
- and
- Acceleration spectral density: 0.3 m²/s³
- Frequency range: 200 Hz to 2000 Hz

The later range can be neglected transporting with vehicles with high damping.

Non stationary vibration, including shock

- Shock response spectrum type I.
- peak acceleration: 100 m/s²
- and
- Shock response spectrum type II.
- peak acceleration: 300 m/s²

*Free fall:

Weight and drop height deviate from 2M2

Tested acc. to internal standard: F23047-A1004-S000-01-76

Specimen Weight [kg]	Drop Heights [mm]	
	Standard Level	Extra Level
up to 9,5 kg	460	760
over 9,5 to 18,6 kg	310	610
over 18,6 to 27,7 kg	200	460
over 27,7 kg	200	310
Number of Drops	3	7

Toppling: Around any of the edges.

Rolling, pitching

- Angle: ±35°
- Period: 8 s

35° may occur for short time periods but 22.5° may persist permanently.

- Acceleration: 20 m/s²
- Static load: 10 kPa

Handling Instructions

for *flow* E3BP packages



Vincotech

13 Handling of trays

The modules are transported in layer of trays and every layer has to be rotated on each other by 180° to guarantee that all the modules are safe. This is also valid any time after unpacking. Figure 30 shows the signs that the trays are in good positioning.

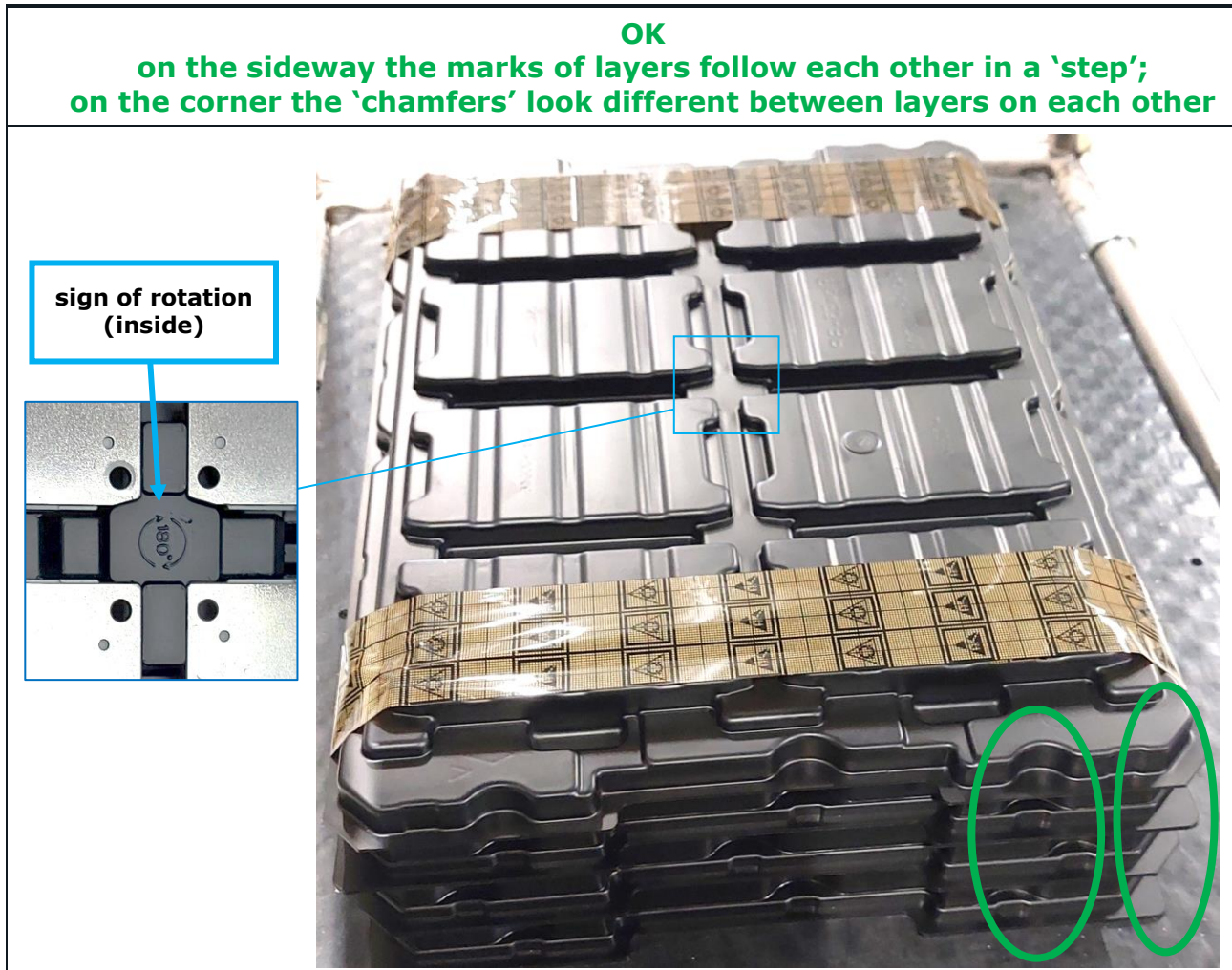

Figure 30: Layer of trays

14 Disclaimer

The information and recommendations in this document are based on standards and common engineering practices. Customer specific applications and specifications may require additional processes and tests that may supersede those recommended in this document.